

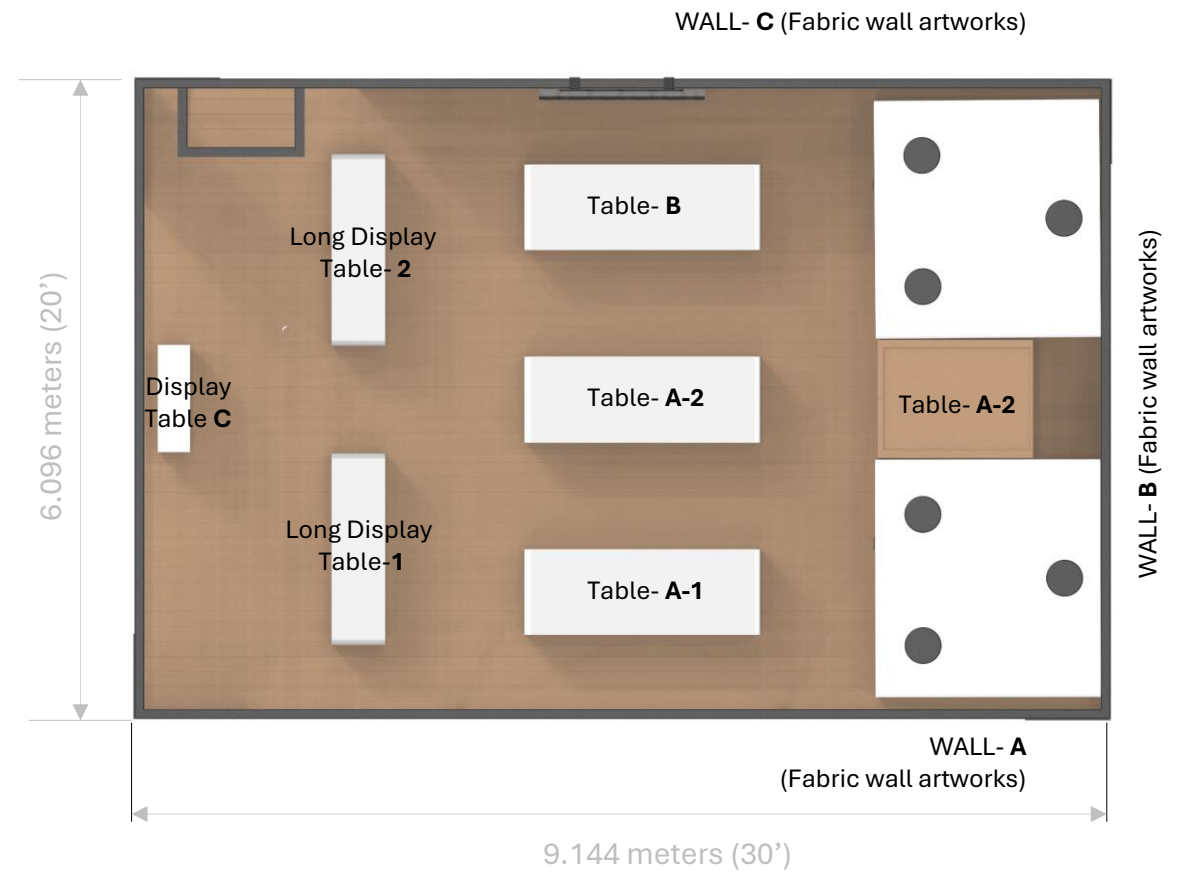

20ft X 30ft Collapsible BOOTH

6.096 meters (20') X 9.144 meters (30')

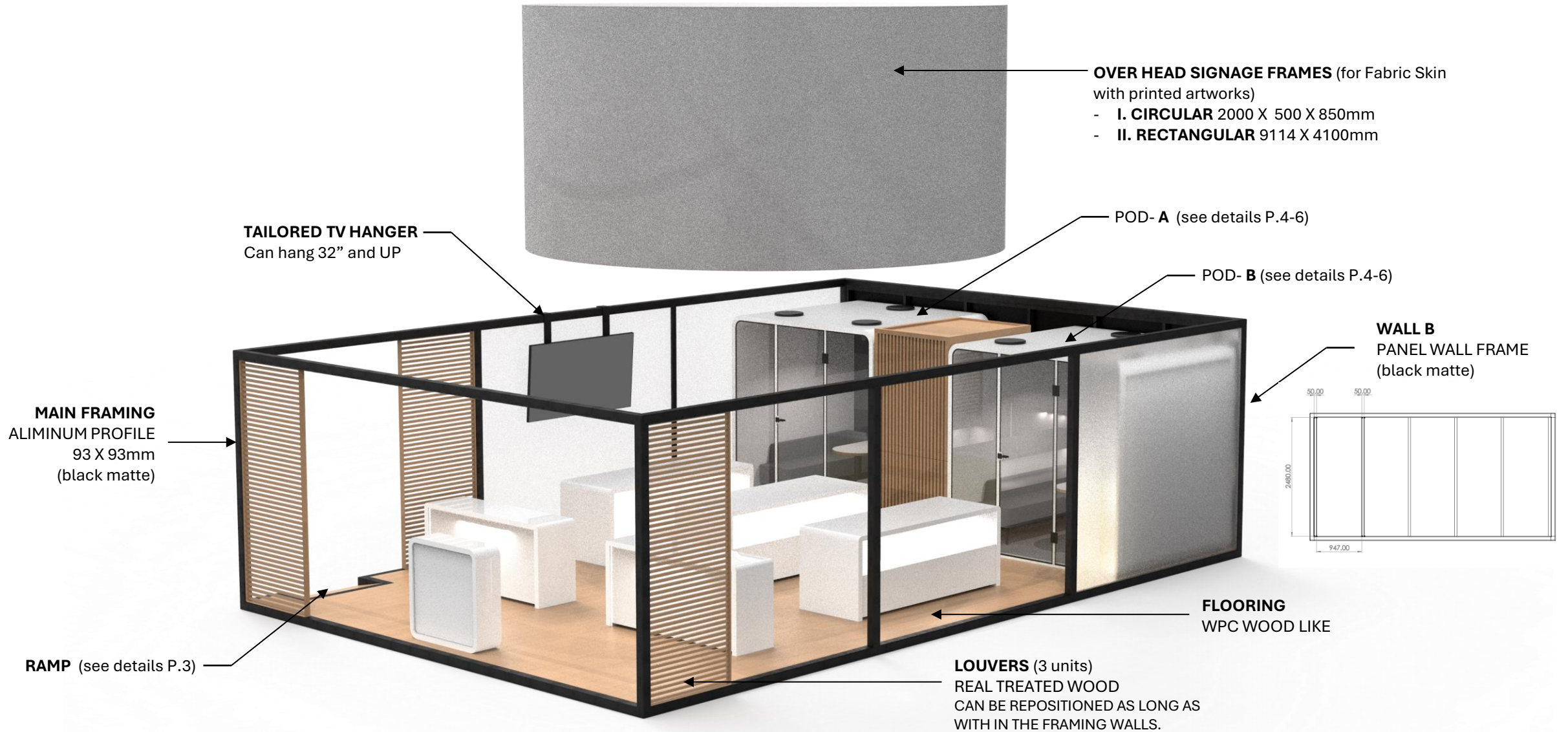



**EXTERIOR**

2200w x 2100d x 2348.5h

INTERIOR

2070w x 2056d x 2128h

SPACE9.06 m³**FLOOR AREA**4.62 m²**GROSS WEIGHT**

740 kgs

NET WEIGHT

580 kgs

PACKAGED

2222w x 1100d x 1250h

UNIT:mm

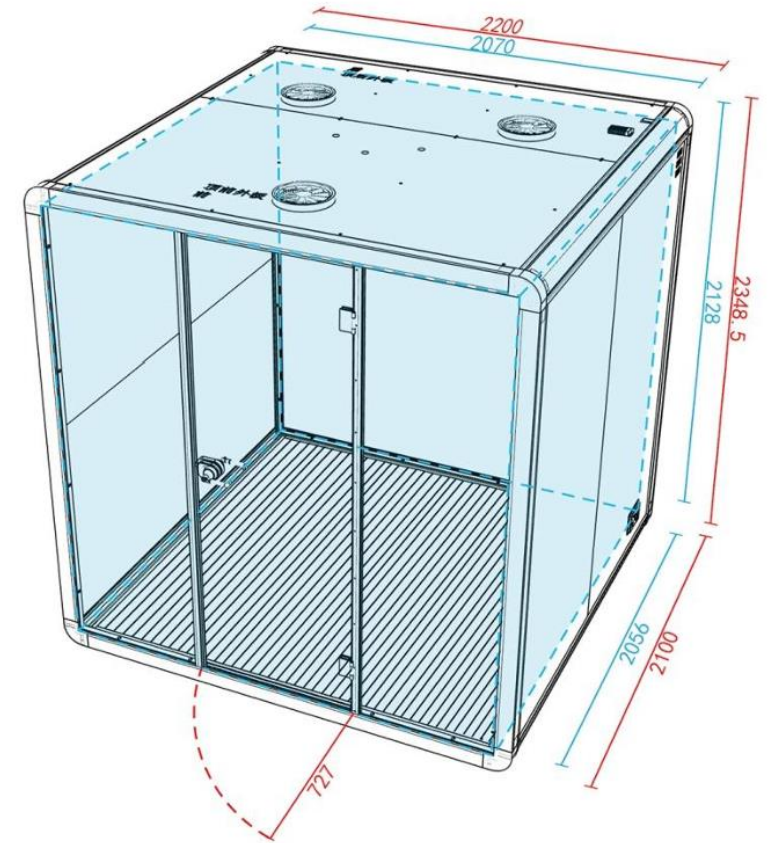
EXTERIOR Dimensions: INTERIOR Dimensions : 





Circular Lighting
Matte Finish Housing
PMS Black



POWER OUTLET AND SWITCHES
-POWER JUCTION x2
-MAIN LIGHT SWITCH / VENTILATION FAN
All Black High Gloss Finish



TABLE
All Metal Frame / Pillars
Matte Finish
PMS Black

TOP & BOTTOM Surface
PMS-STD White

SIDE TRIM / EDGING STRIP
PVC
PMS STD-Wood like finish



Interior Side Walls
As per standard material
PMS L-Grey

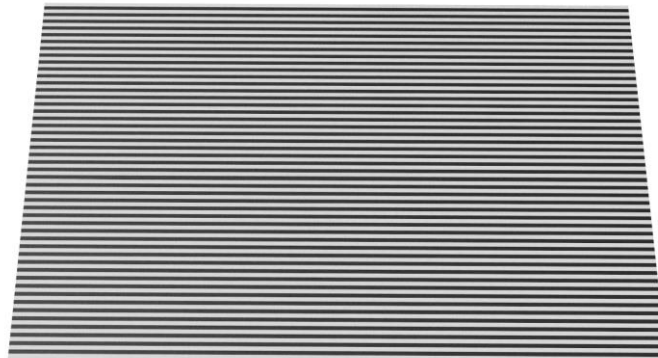

Flooring
As per standard material
PMS Grey and Black

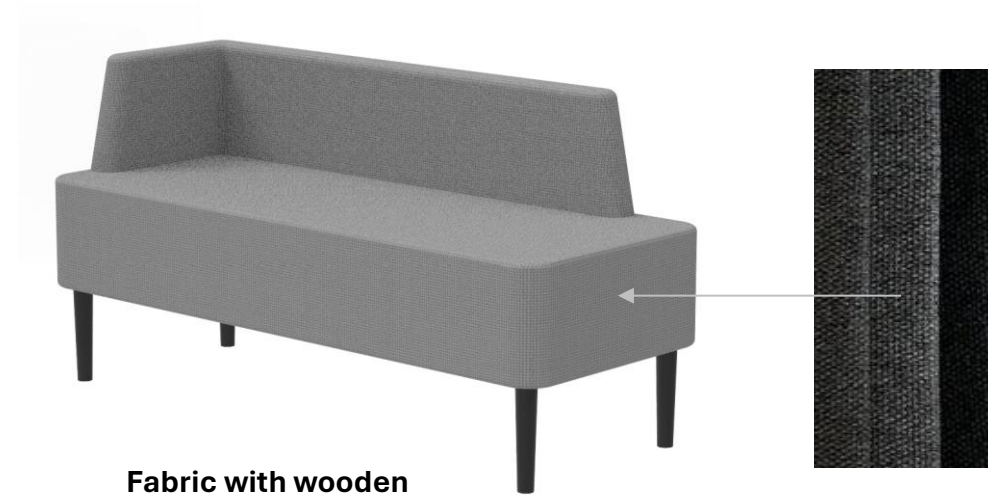

Fabric with wooden
Matte Finish
PMS Black

Display Table A (2-Units)

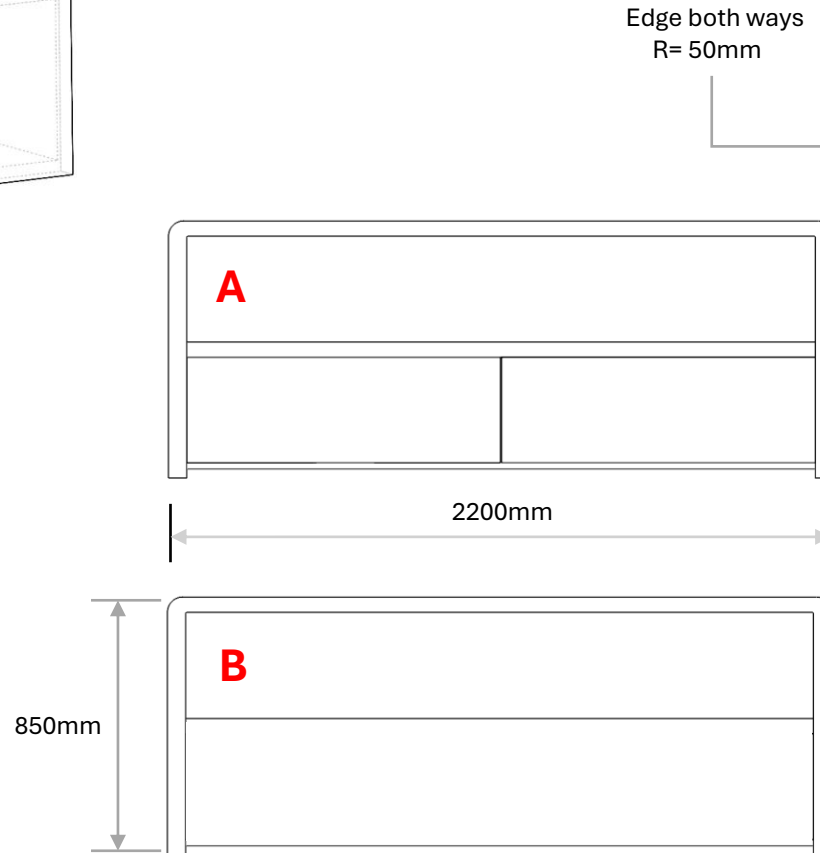
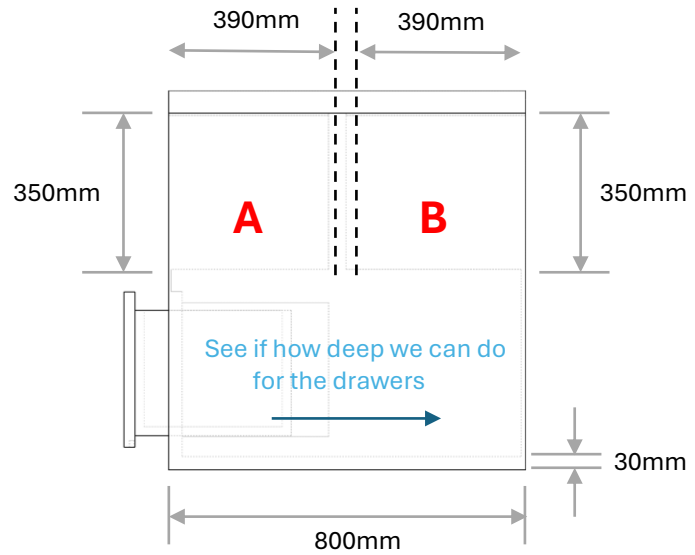
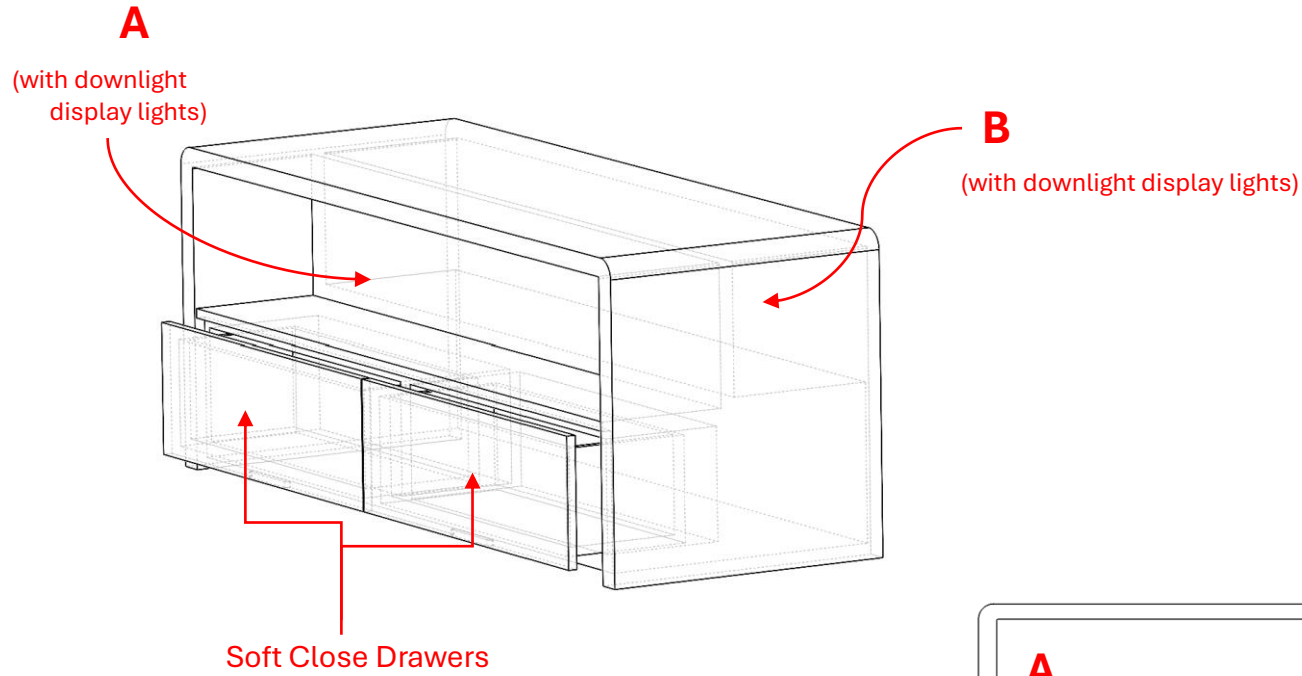

Display Table **B** (1-Unit)

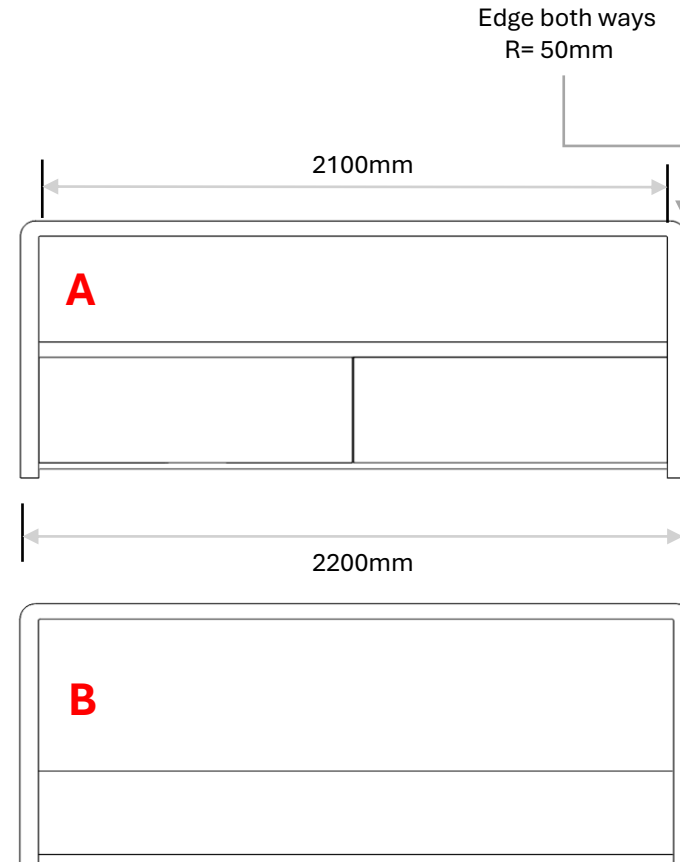
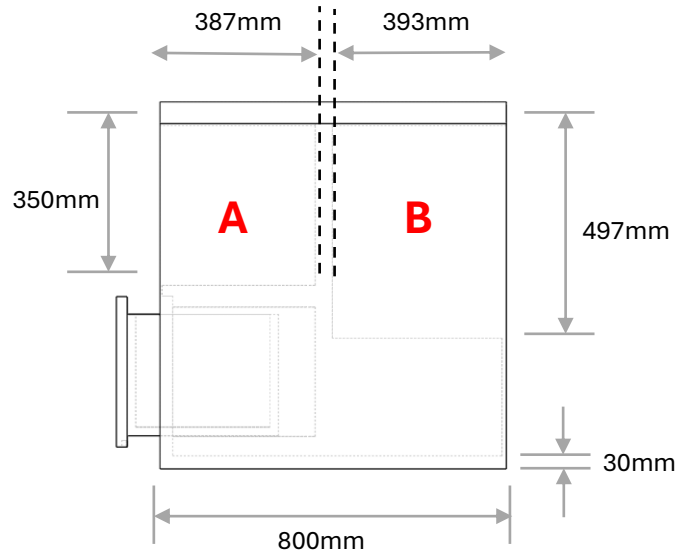
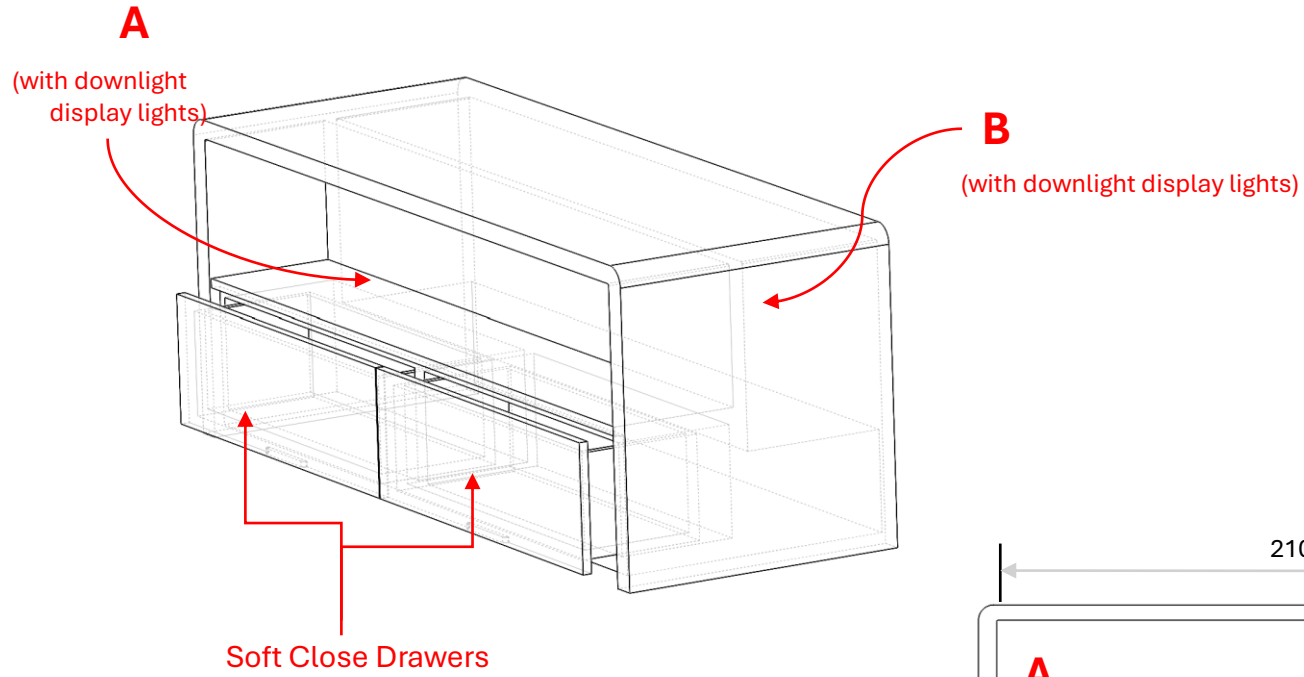

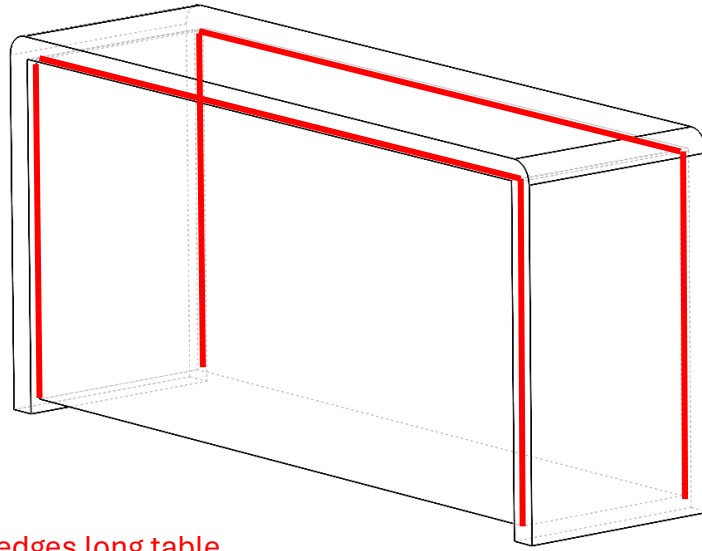

*NOTE: Strip lights at RIM edges long table.

Long Display Table C (2-Units)

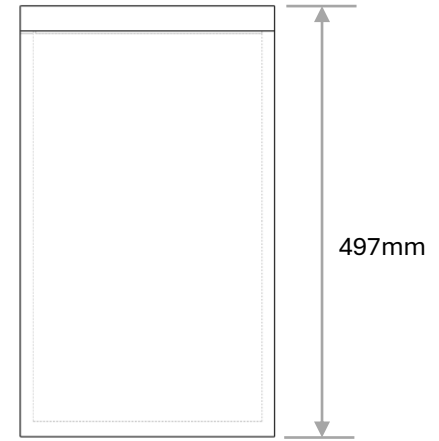
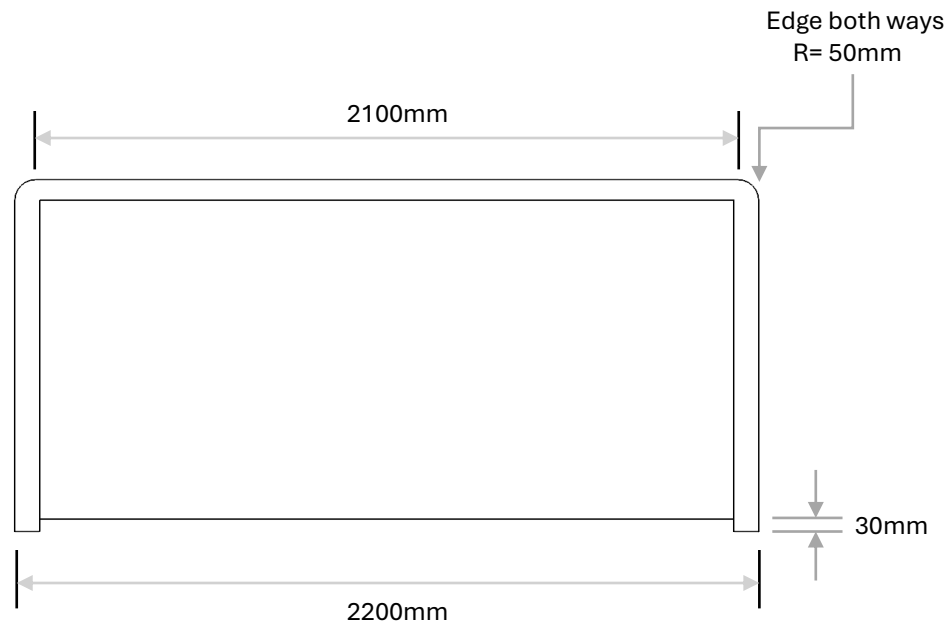

Display Table C (1-unit)

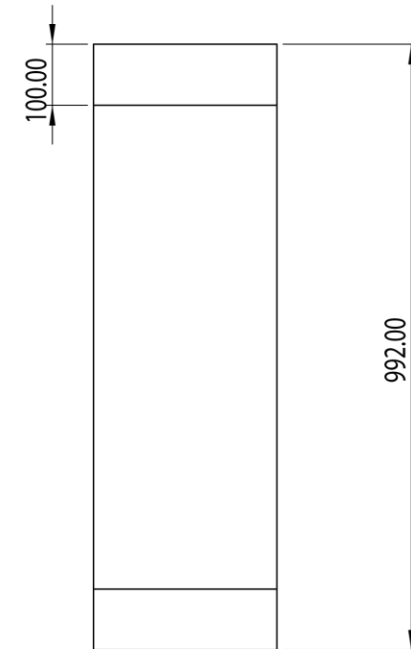
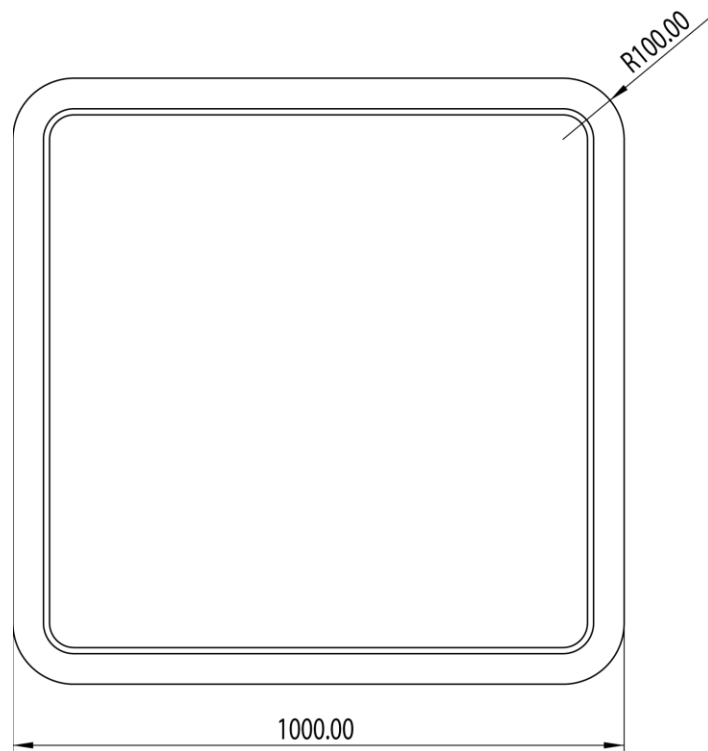

Display Table C (2-units)

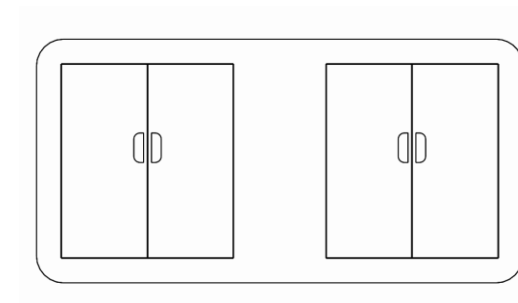
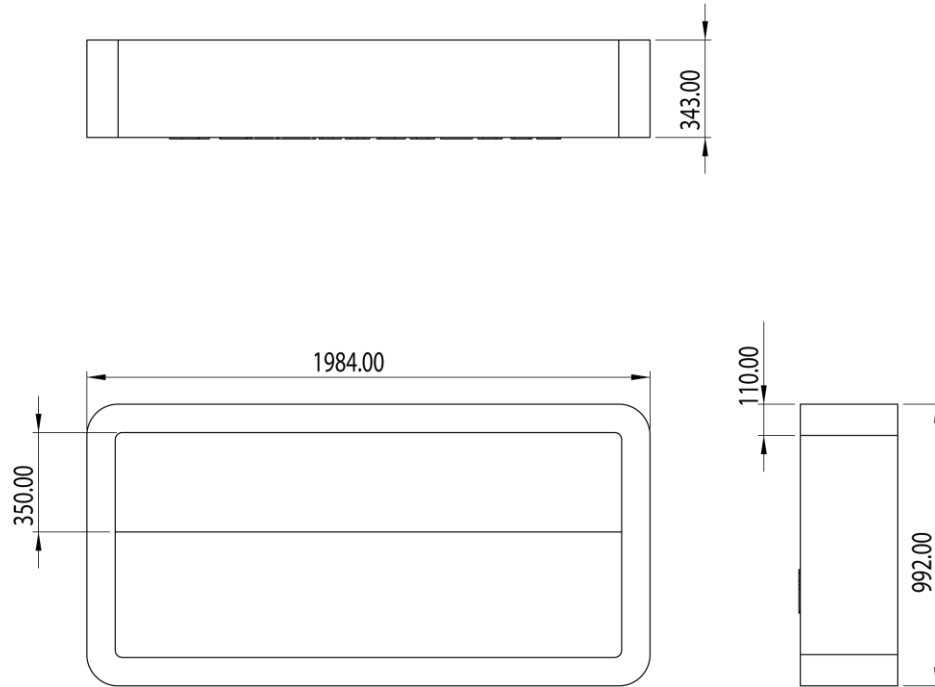

With back storage

Mobile Table with Storage (1-unit)

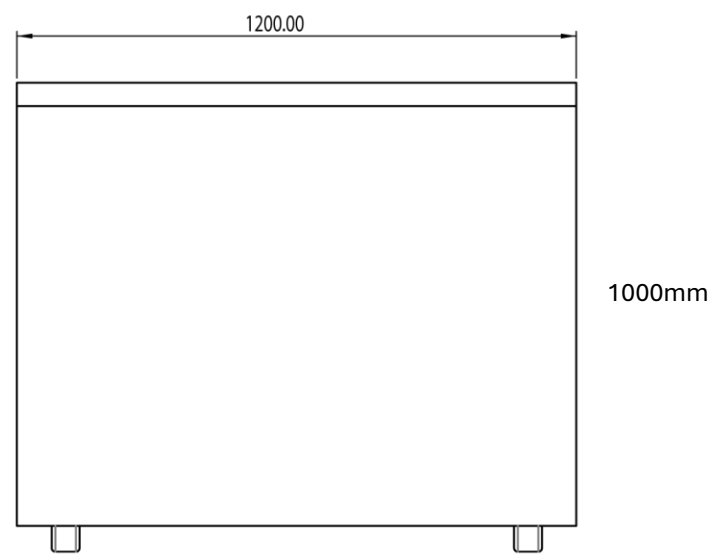
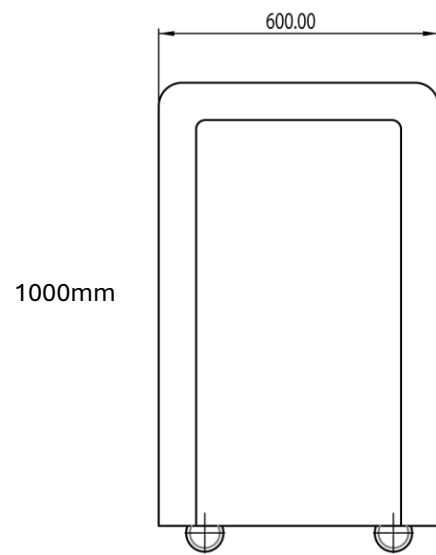
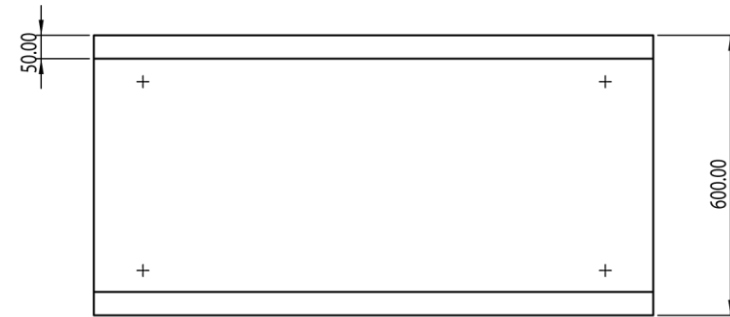
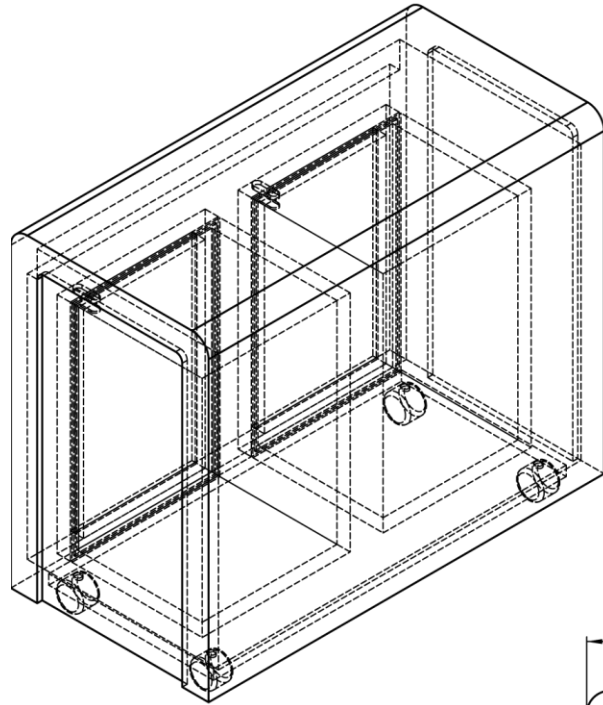

Cabinet with Pullouts (1-Unit)

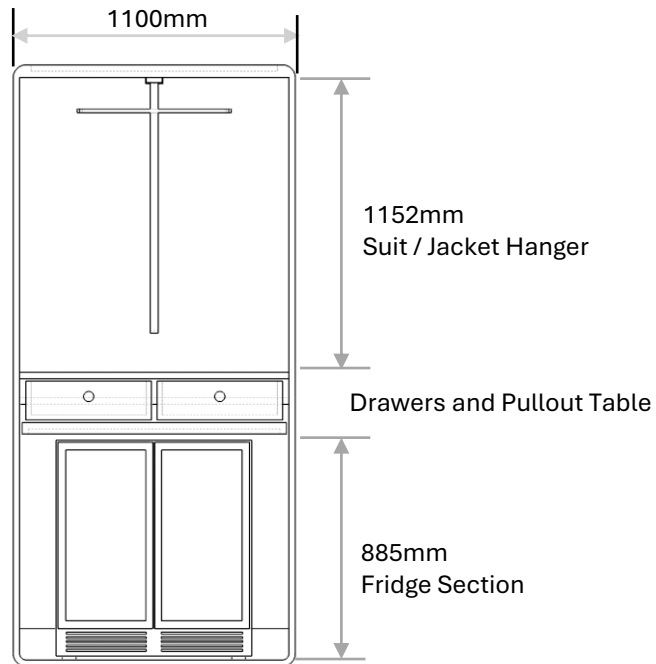
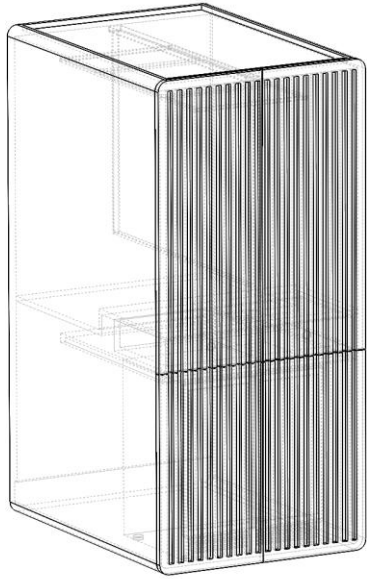

Pull-out Hanger same as the current cabinet

2 drawers

Recessed for dropping plants
And door fronts

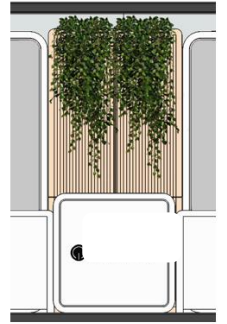

Side Finishing
Option A- With vertical ribs
same as the door.
Option B- Plain without ribs

Pull-out Table (lower section)

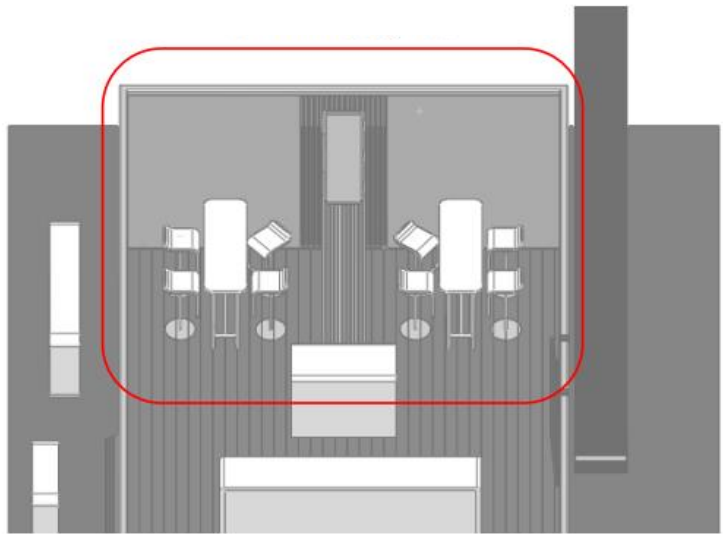

Bar Table and 4 Bar seats

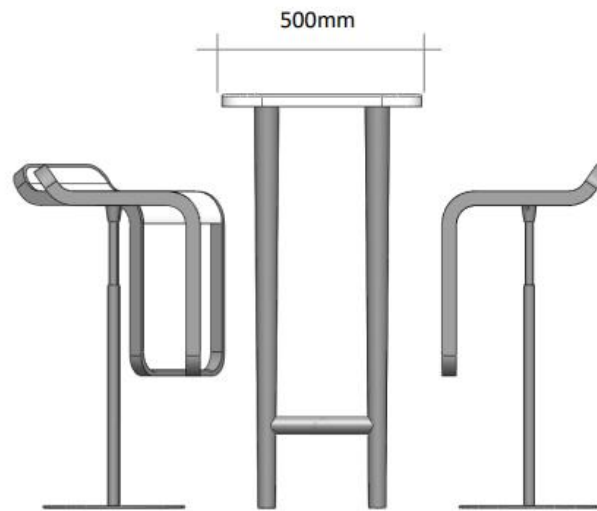
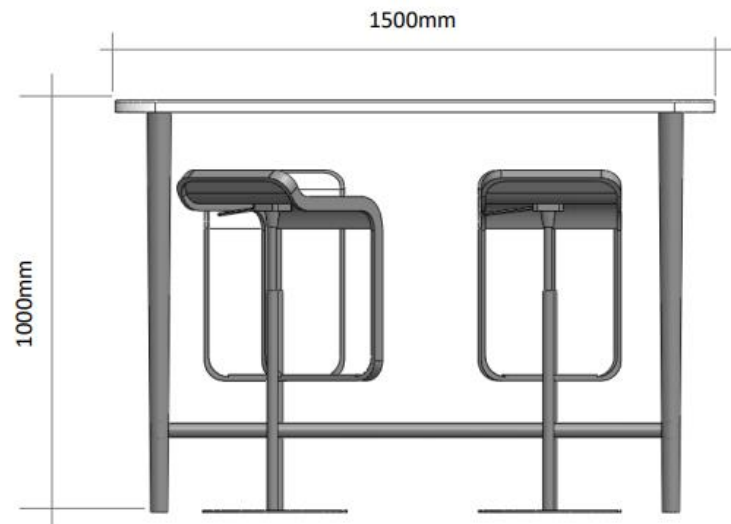

*ACTUAL BAR CHAIRS OUTLOOK

T H E E N D