

COMPONENTS

(B3) Panel B3	4x
(BT) Blimp Tower	1x
(C) Counter	2x
(WF) 36" Waterfall	2x
(WS) Waterfall Shelves	6x
(WB) WLM to BLM 90	2x
(B-TV) BLM-TV-36	2x

WB-90

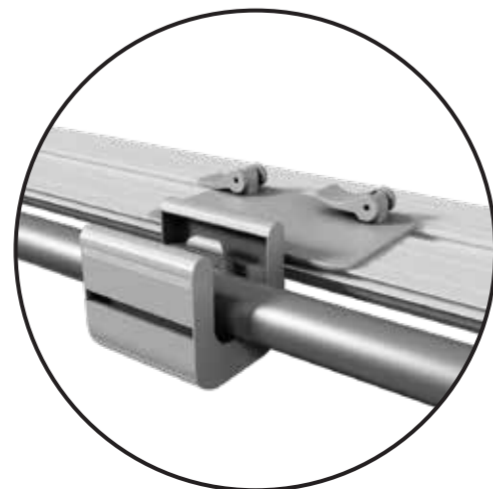

Monitor Mount
BLM-TV-36-K

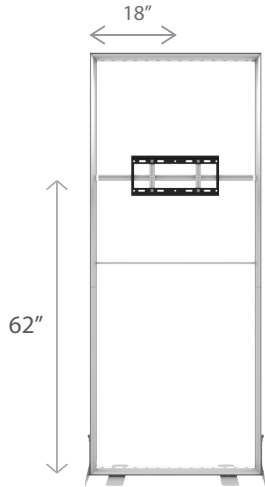

PRODUCT DESCRIPTION

Designed for compatibility with BrightLine and StraightLine Displays, these mounts deliver a captivating "floating" screen sensation. Simply slide the TV bar into the frame, secure the monitor plate with screws, and attach your screen on the front. Side feet are included in the kit for extra stability. Graphics can be finished with four small pre-cut slits for convenient access, or you can customize your own cutouts as required.

MONITOR SPECIFICATIONS





Holds monitors up to 25 lbs, VESA 200 X 200

DIMENSIONS

Shipping Box

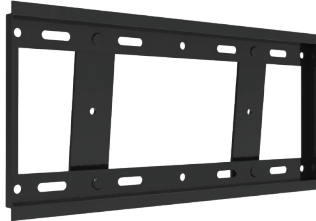
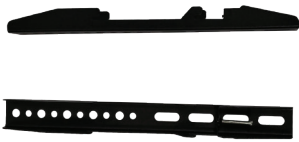
14" w x 4" d x 42" h, 8 lbs

PARTS

(1x) Allen Key	 5mm	 
(4x) Bracket-to-Monitor Screws: M5, M6, & M8 screws included. Check your TV for specs		
Spacers		
Cutter		

Monitor Plate

Monitor Brackets
(2)



(2) M6 screws

TV Bar 36"



Side Foot
(2)

*Philips Screwdriver not included

Monitor Mount

BLM-TV-36-K

BrightLine

StraightLine

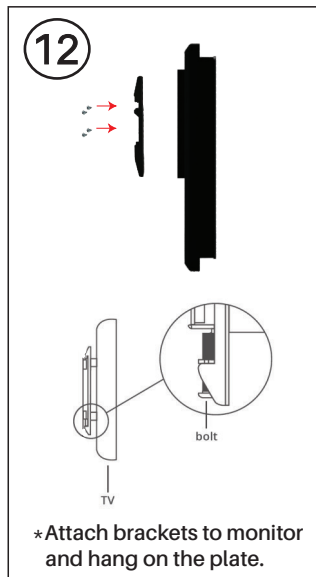
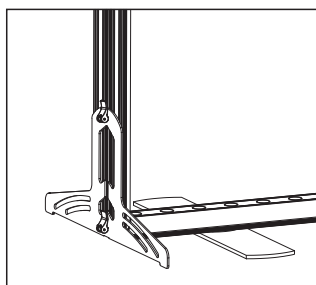
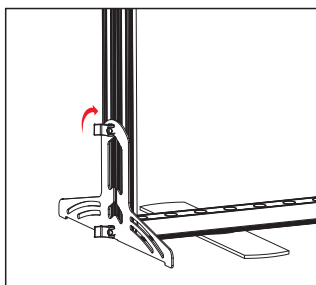
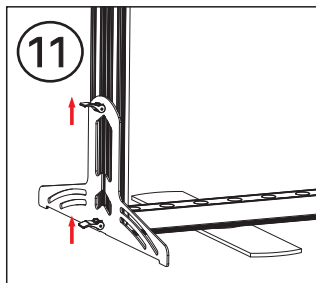
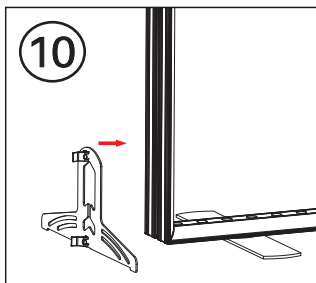
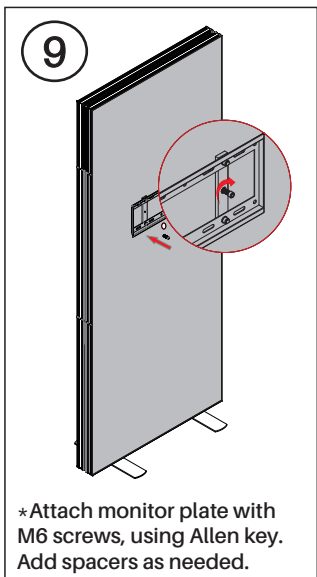
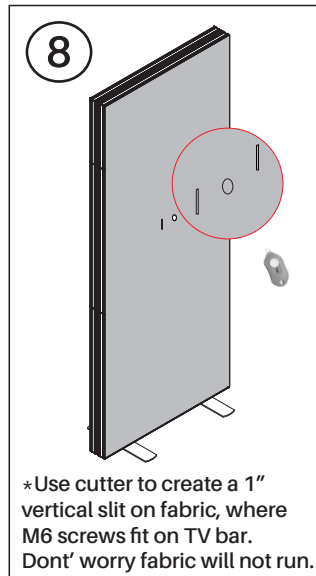
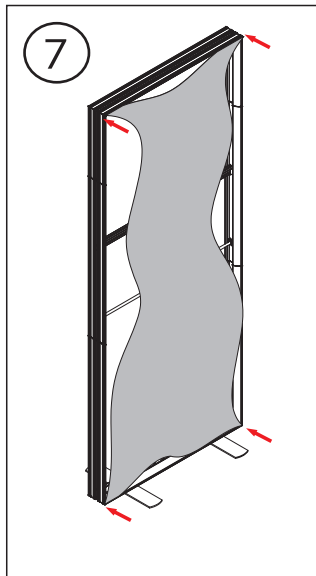
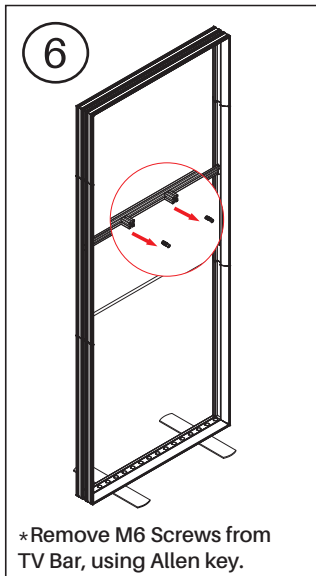
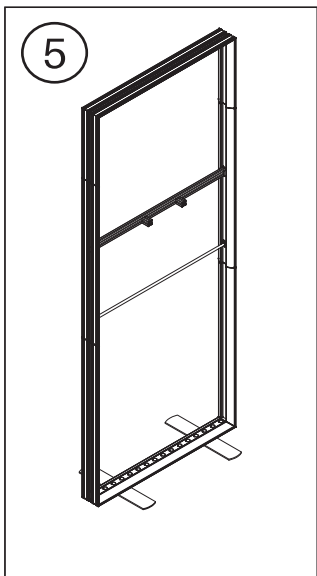
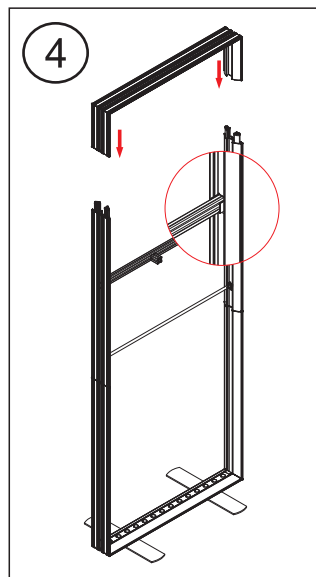
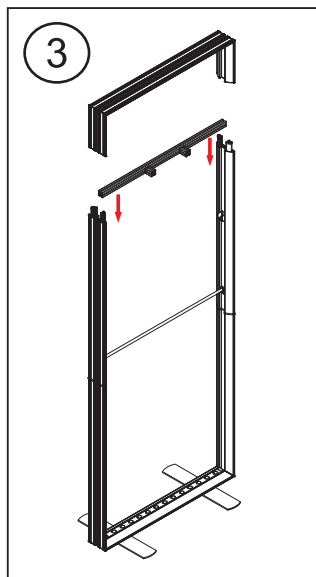
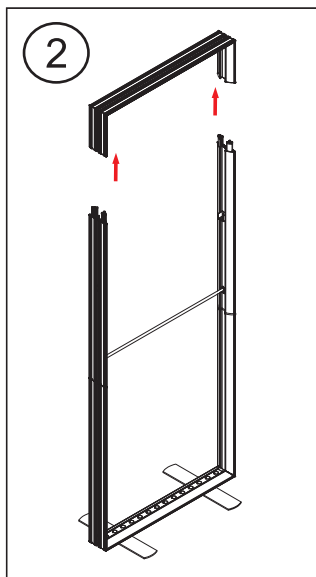

PARTS INCLUDED

Adhesive Cable Clips (4x)



Reusable Velcro Cable Ties (5x)



Resealable Lock Bag



You will need 10ft Extension Cable

1

Connect the extension cable to your TV. Route cable inside the groove of the TV bar and use cable ties to secure in place.

2

Attach wire clips to the frame. Then route the cable through and secure within the clips.

3

Route cable through the bottom corner of the frame.

4

Secure the vertical end of the graphic first, adjust cable, then finish with the bottom of the fabric

Waterfall 36"

WFA36

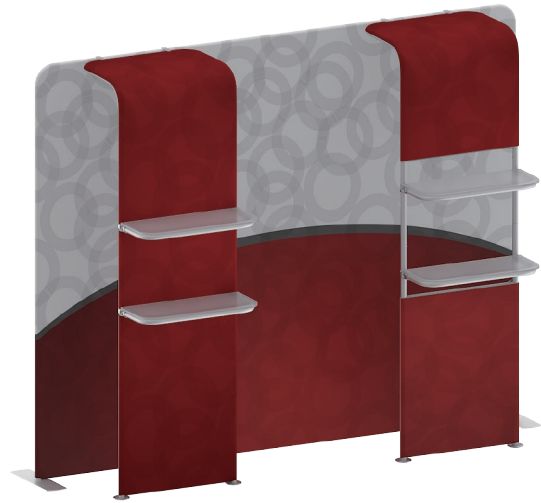

Partial Graphic
WFA36-G-P

FullGraphic
WFA36-G



PARTS INCLUDED



Aluminum Frame



Graphic



Support Feet x2



WLM-CM90 Clamp x1



OPTIONAL Shelving

PRODUCT DESCRIPTION

The WaveLine Waterfall features a robust aluminum frame with choice of partial or full graphics. Its durable aluminum poles are supported by sturdy feet. Graphics are printed on exclusive One Planet recycled fabric. Upgrade with optional shelving for more functionality.

KEY FEATURES

- Provides additional depth and functionality
- Easy tool-free assembly
- Durable aluminum poles
- Partial or full graphics
- Vibrant graphic prints on recycled fabrics
- Convenient optional shelving

DISPLAY CONSTRUCTION

Aluminum frame with aluminum support poles

GRAPHIC FINISHING

Top grade YKK zippers along bottom of display

GRAPHIC MATERIAL

Graphic Print :
Dye sublimated on One Planet, 100% recycled, fabric

Bottles recycled
59

DIMENSIONS

Assembled Unit	36"w x 89"h x 21"d
WFA-G Graphic Size	36"w x 105"h
WFA-G-P Graphic Size	Top: 36"w x 39.8"h Bottom: 36"w x 35.4"h
Shipping Box	33"w x 14"h x 11"d, 16 lbs
Optional Shelves	Call for details!

WARRANTY

Limited Warranty Periods
- Frame : Lifetime
- Graphics : 6 months

Waterfall 36"

WFA36

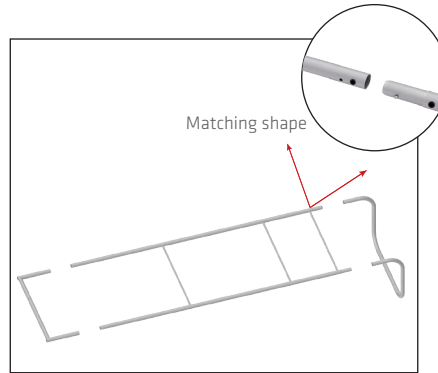
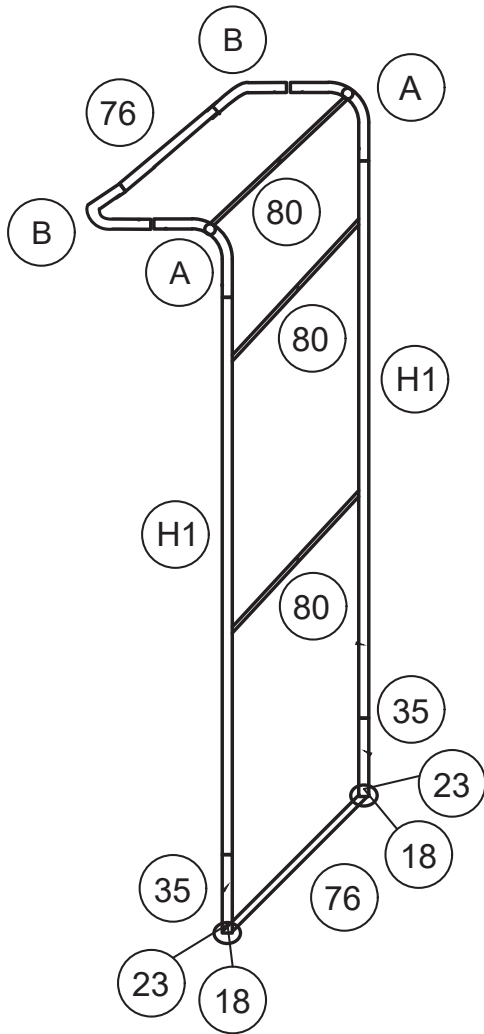

1. Connect poles by pressing and pushing. Connect corner sections to straight sections with matching shape codes.

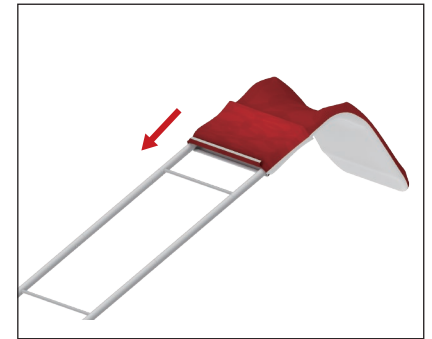

2. Unzip print and lay image face up. Slide print onto frame like a pillow case.

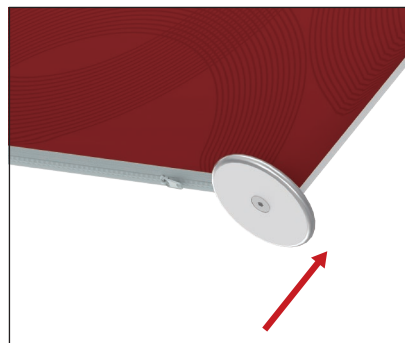

3. Connect feet by pressing and pushing. Zip the bottom edge of the graphic beyond the center point as shown above.



4. Position frame as desired and clamp in place.

36" Waterfall	
Qty.	Part Number
2	WLM90 (A)
2	WLM90-1 (B)
2	WFA-H-1 (H1)
3	WLM-80 (80)
2	WLM-76 (76)
2	WLM35 (35)
2	WLM18 (18)
2	WLM23 (23)
1	WLM-CM90

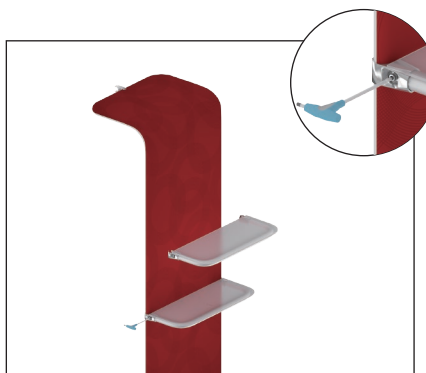

5. Shelves come semi assembled, make sure to level before tightening the clamp.



6. Enjoy!

WAVELINE® SQUARE TOWER-BST42

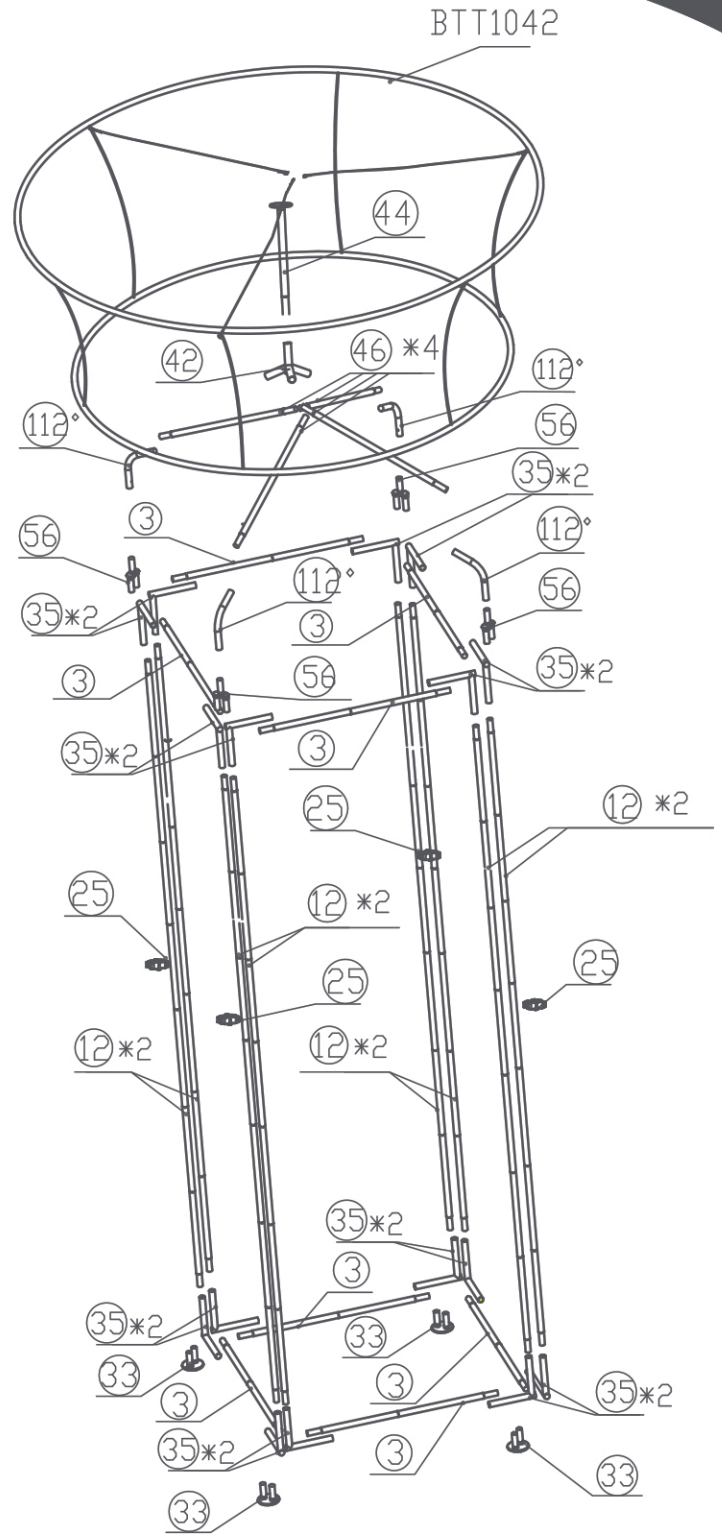
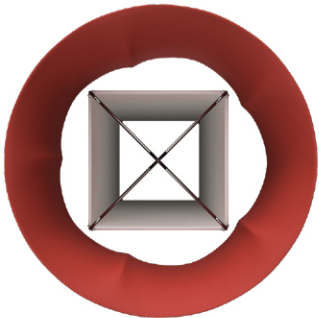
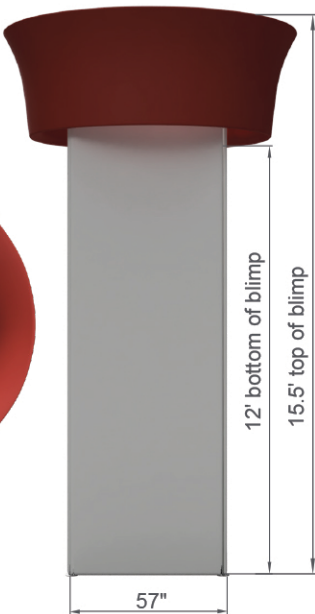

Frame		Frame		Frame		Frame		Shipping Case		
③③	4	④②	1	BTT10	1				NYLON BAG	
③	8	④④	1	BFP42	6					
③⑤	16	②⑤	4	CABLE	1.5	-	3pt.	1		
①②	8	⑤⑥	4							
④⑥	4	①①②°	4							
NO.	Quantity	Confirm	NO.	Quantity	Confirm	NO.	Quantity	Confirm	NO.	Confirm

Setup Instructions

Blimp Square Tower

TOOLS

No tools required

PARTS

(A) 16 straight poles:
8x part 3
8x part 12



(B) 16 straight corner poles: part 35



(C) 4 double circular feet: part 33



(D) 4 90 degree clamps



(E) 4 fabric graphics



(F) 4 top support post: part 56



(G) 4 rounded corner poles: part 112



(H) 4 square tower support poles:
part 46



(I) 1 4-way connector pole: part 42



(J) 1 carousel pole: part 44



STEP 01

Assemble straight poles (A).

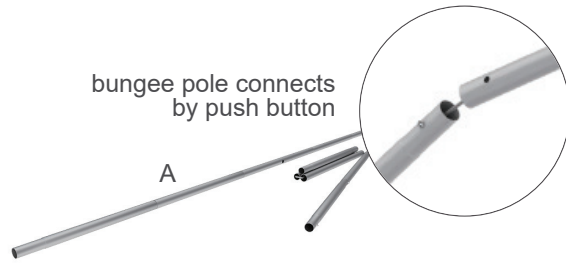

STEP 02

Connect corner poles (B) to straight poles (A) with matching shape codes. Connects by push button.

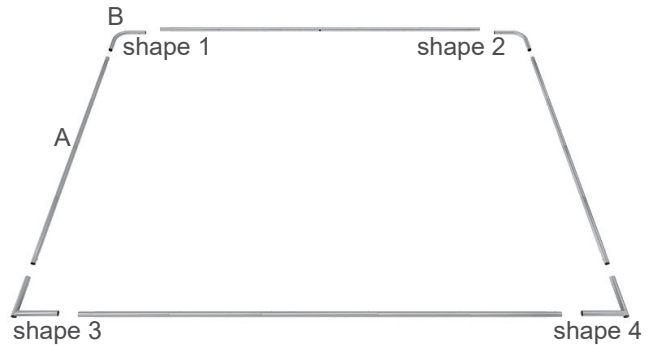

STEP 03

Repeat step 2 for the other three corners.

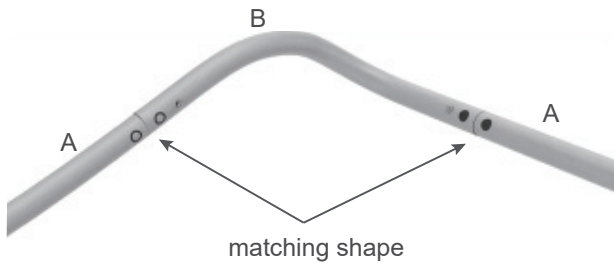

STEP 04

Unzip fabric graphic (E) and lay image face up. Slide fabric onto frame like a pillow case. Pinch graphic closed at bottom to zip up.

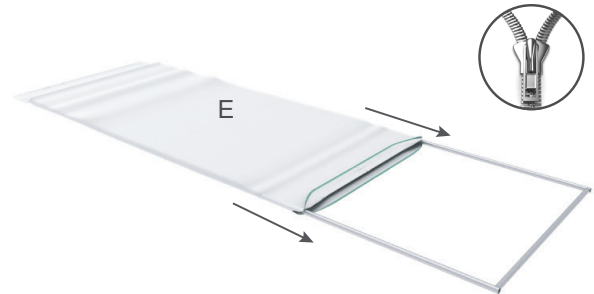

STEP 05

Repeat step 1-4 for the other three display panels. Install bottom circular feet (C) by joining two panels together and inserting dual posts into bottom of frame corners. Install 90 degree clamps (D) between panels for stability. Do this for all four sides of the tower.

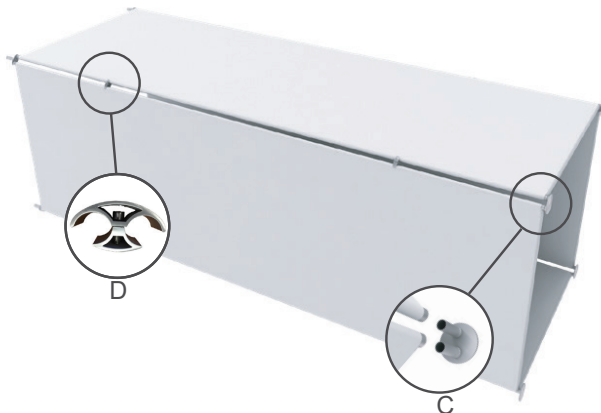

STEP 06

Install top support posts (F) by joining two panels together and inserting dual posts into bottom of frame corners. Do this for all four sides of the tower.



STEP 07

Assemble canopy frame by pushing and pulling round corner poles (G), square tower support poles (H), and 4-way connector pole (I) together.

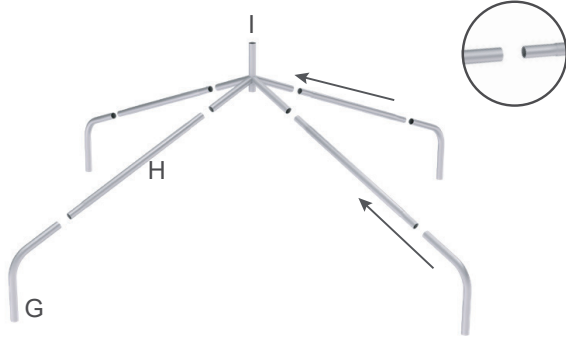

STEP 08

Connect canopy frame to the tower. Insert center carousel pole (J) by running the power cord down through the canopy frame center pole and pushing into place.

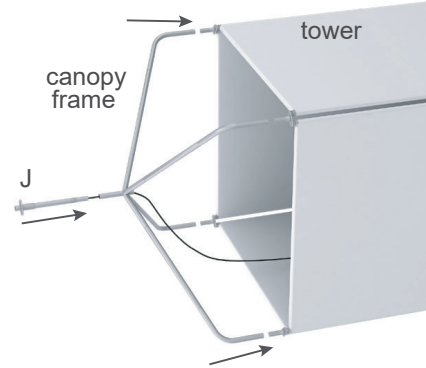

STEP 09

See tapered tube instructions for top hanging sign.



STEP 10

With tower and hanging sign on their sides, attach hanging sign to center carousel pole (J) using cables and clips. Push tower up into position.

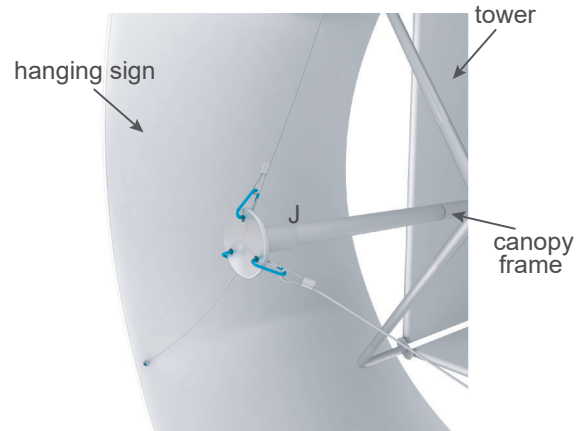

STEP 11

Complete.



QUICK VIEW

Hardware configuration.

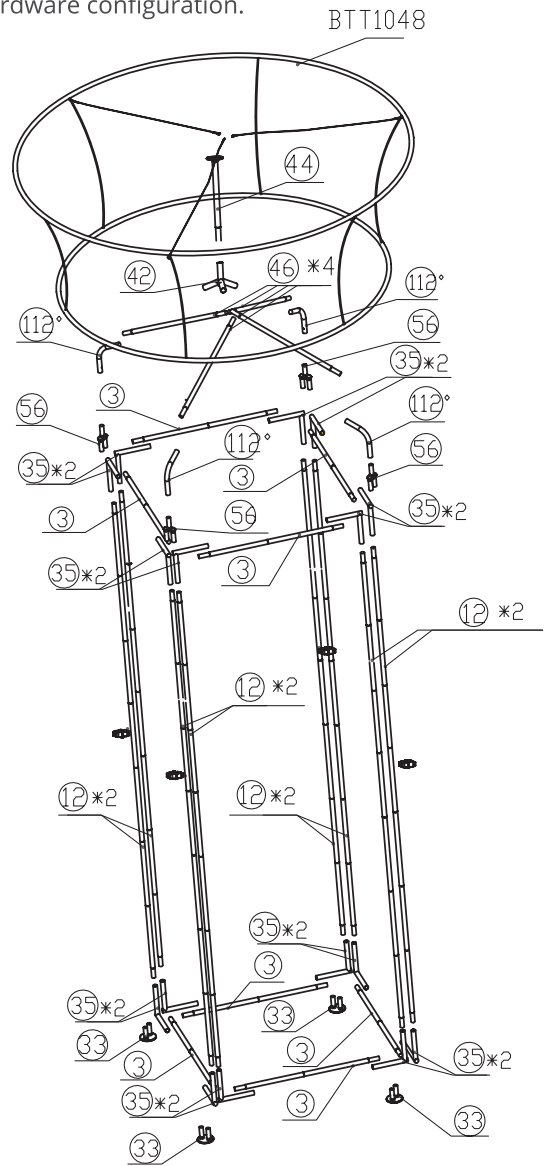

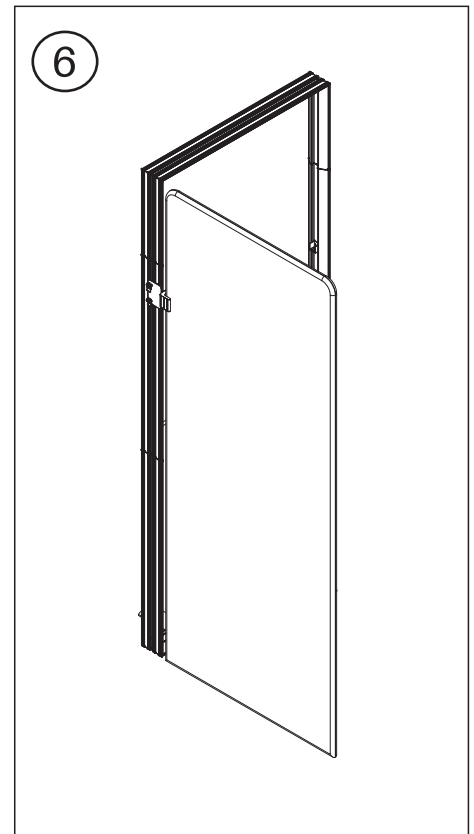
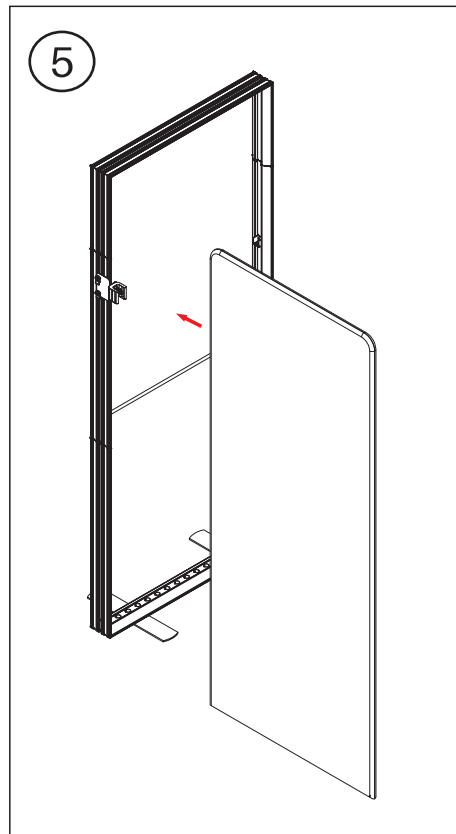
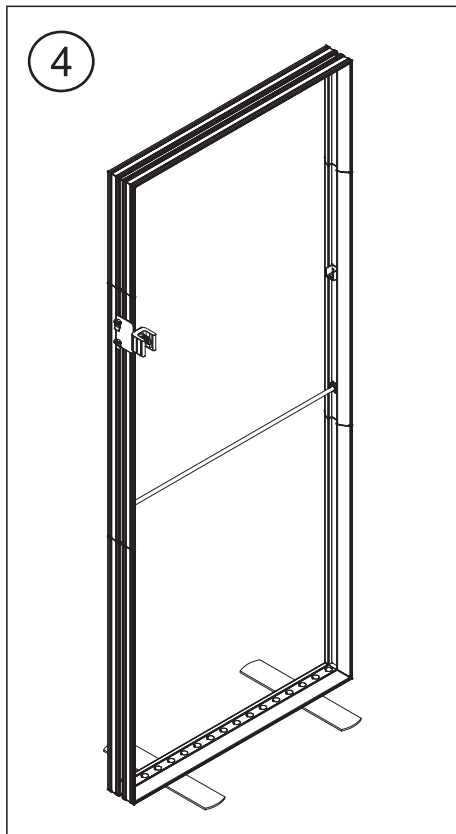
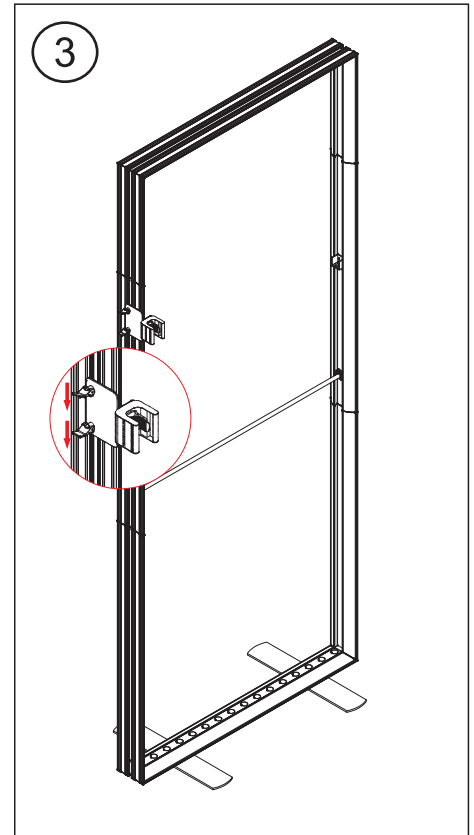
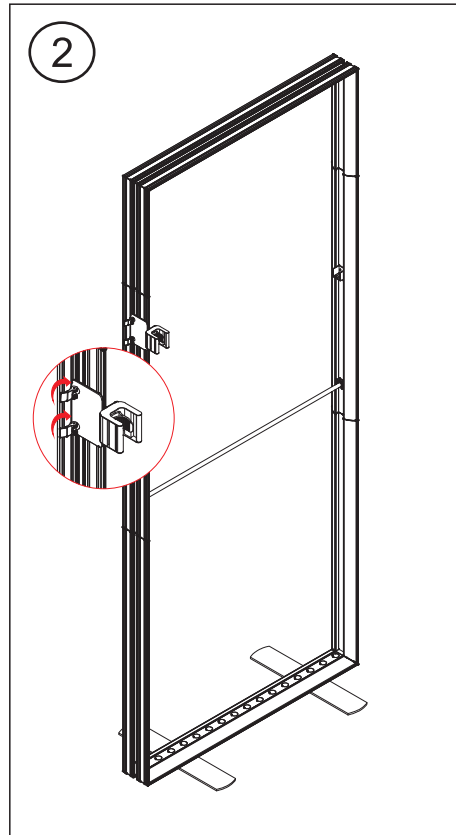
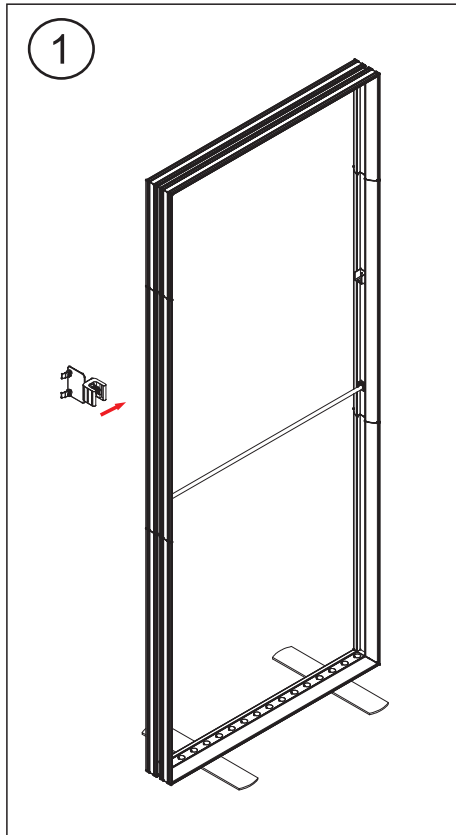

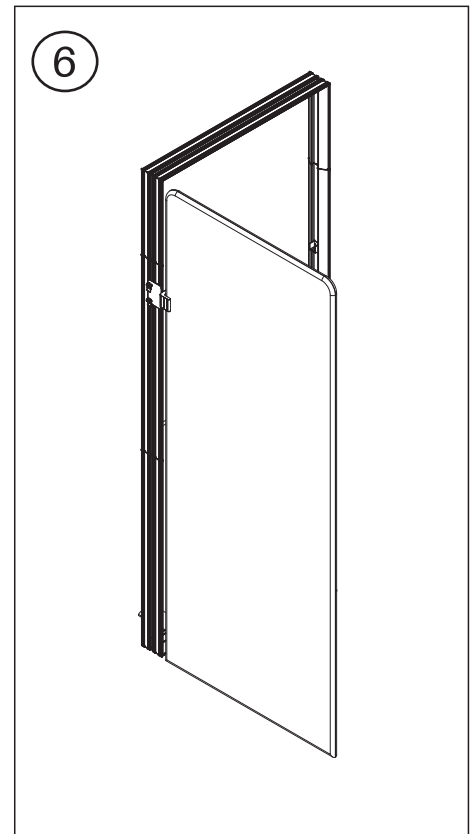
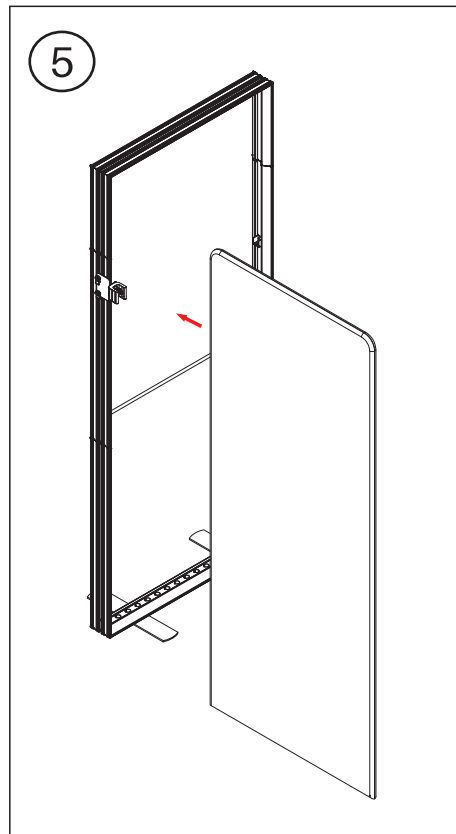
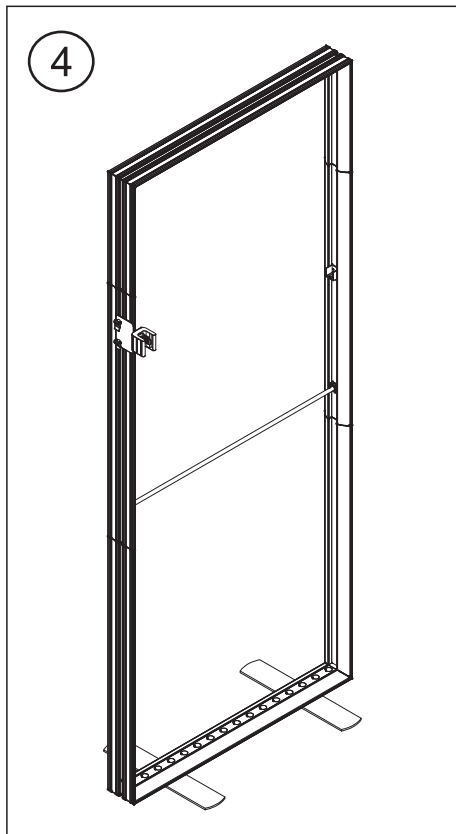
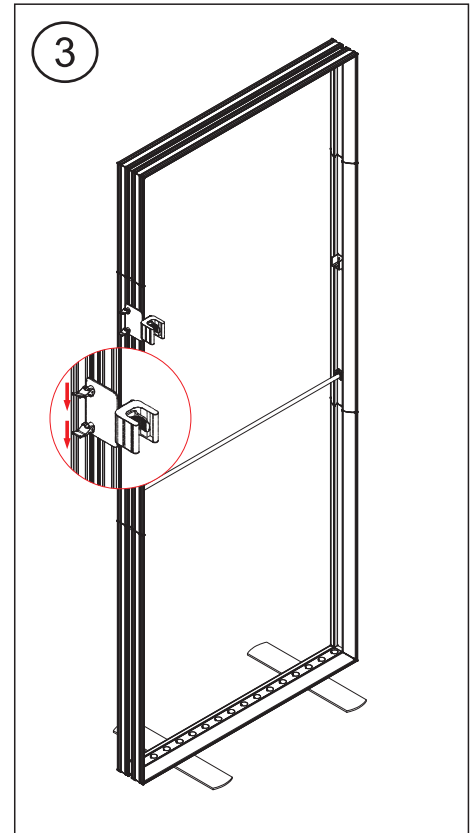
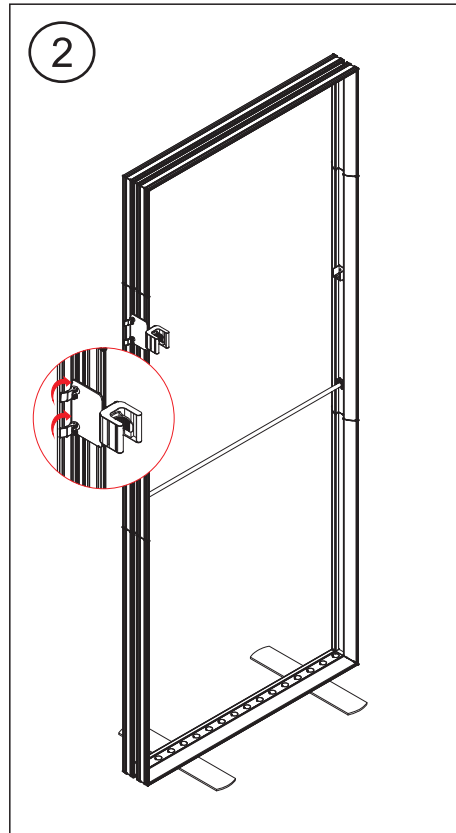
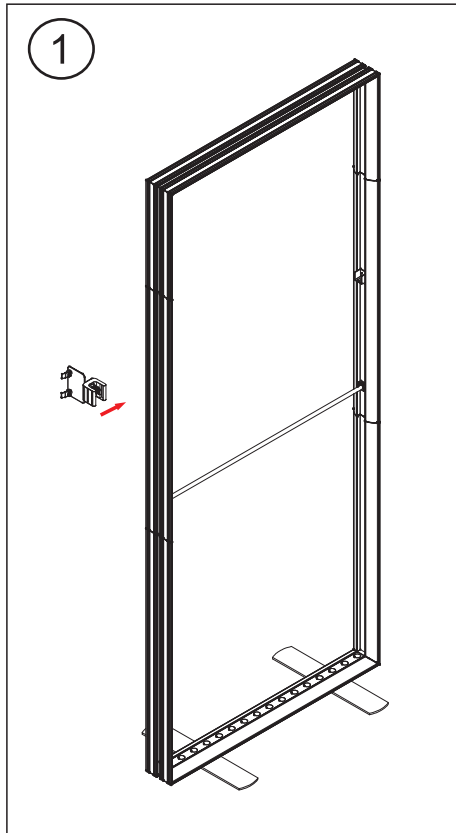

Counter
BLM-COUNTER-K

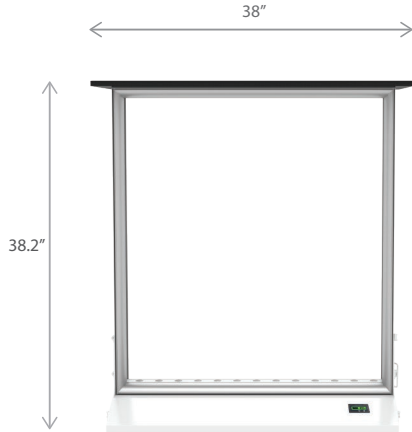

PRODUCT DESCRIPTION

The BrightLine backlit counter stands as a beacon of sophistication, seamlessly blending illumination, and functionality. Its sleek design, showcasing double-sided graphics, creates an ambiance that draws attention. Complete an inviting environment with brilliant counters showcasing double-sided branding and ample countertops that fit laptops or tablets.

Upgrade to the cordless version, where the base is loaded with rechargeable batteries that last over 12 hours. Whether in a showroom, a tradeshow exhibit, or a retail environment, the backlit counter defines a modern elegance and functionality in perfect harmony.

KEY FEATURES

- Easy tool free assembly
- Lightweight portable construction
- Magnetic power links
- LED lights encapsulated in frame
- Heavy duty shipping case, molded foam inserts
- Single- or double-sided
- Vibrant graphics on recycled fabric

DISPLAY CONSTRUCTION

Aluminum frame with aluminum support poles

DIMENSIONS

Assembled Unit	38" w x 38.2" h x 15.8" d
Packed Case	43" w x 23" h x 13.5" d, 59 lbs
Shipping Box	44" w x 23" h x 14" d, 61 lbs
Graphic Size	33" w x 36" h
Countertop	38" w x 0.625" h x 15.75" d
Base	33" w x 1.6" h x 15" d
Graphic Frame	33" w x 36" h x 4.8" d

GRAPHIC MATERIAL

Graphic Print : Dye sublimated on One Planet, 100% recycled, backlit fabric	Bottles recycled 9
Blocker : One Planet light block recycled fabric	Bottles recycled 4

GRAPHIC FINISHING

Silicone sewn edges

LED LIGHT SPECIFICATIONS

Power Requirements	64 W
CCT (Color Temp)	6000 K
Voltage Input	110 / 220V
Voltage Output	24V 4A 96W
Transformers Included	1

WARRANTY

Limited Warranty Periods

- Frame : Lifetime
- Lights : 90 days
- Graphics : 30 days

