

10' F-DD Kit Map

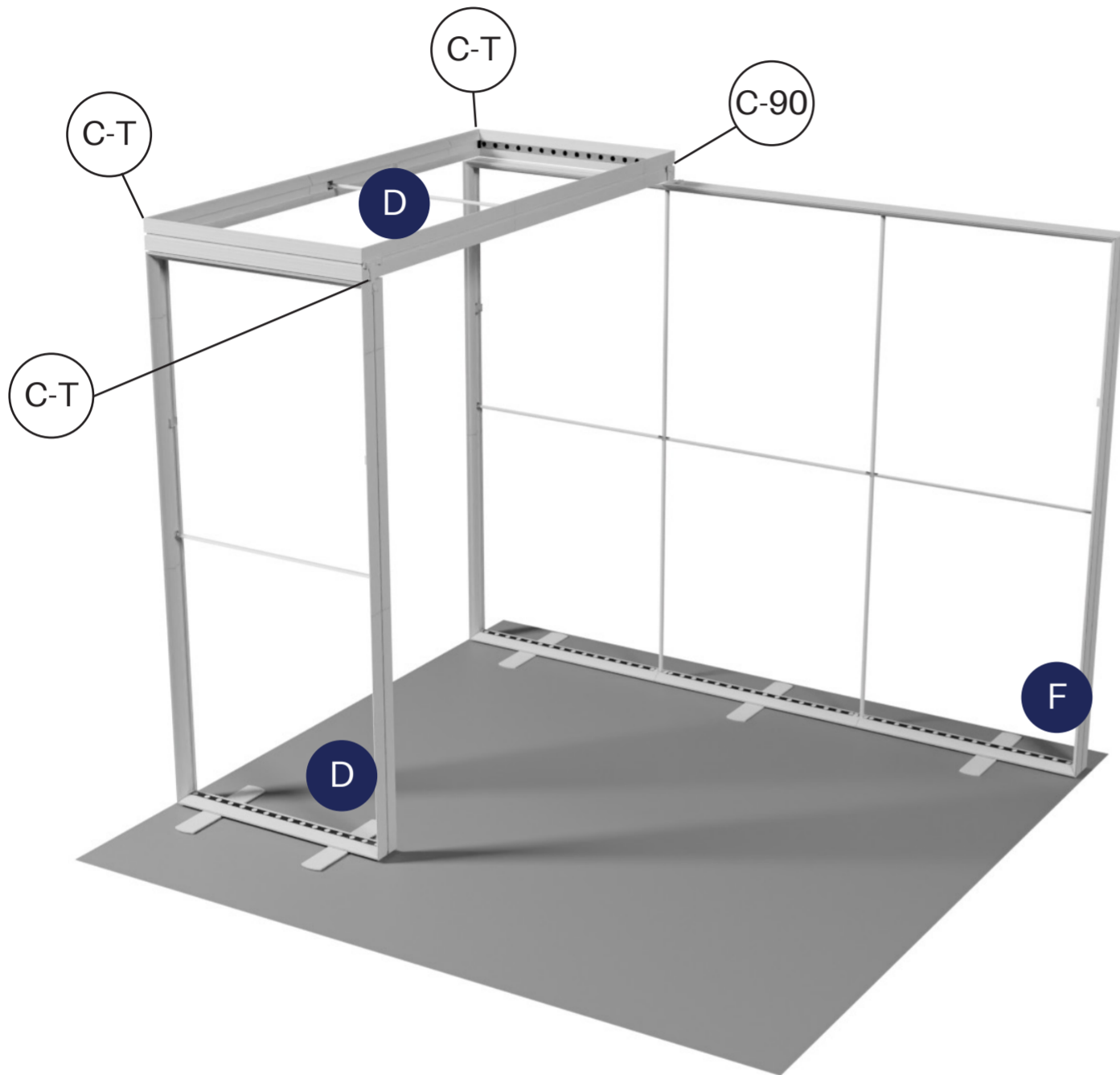

COMPONENTS	
(F) Panel F	1x
(D) Panel D	1x
(C-T) Connector T	3x
(C-90) Connector 90	1x

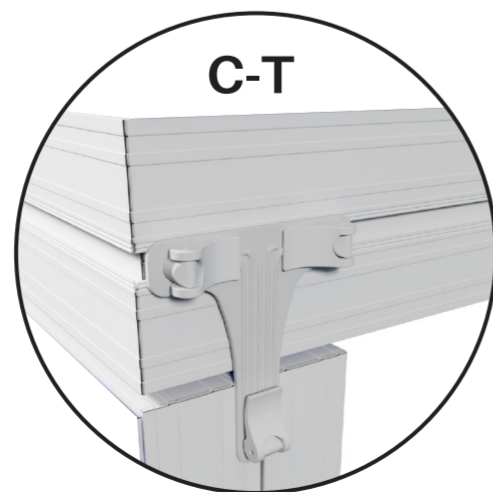

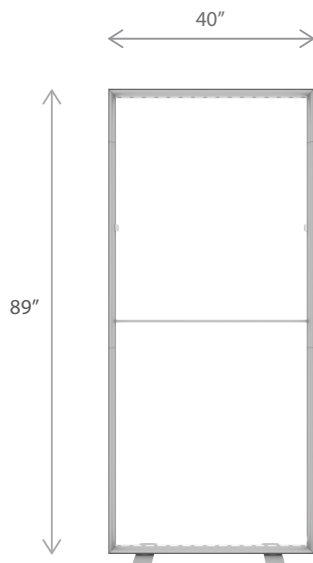

PRODUCT DESCRIPTION	
<p>BrightLine smart light box displays feature swift tool-free installation, durable light-weight frames, embedded LEDs, and exclusive One Planet recycled fabrics with impressive vivid graphics, all conveniently organized in a heavy-duty shipping case. Panel D is sized for versatile applications, as a stand-alone banner or combined to create popular 10 foot and 20ft exhibits.</p> <p>Mix-and-match with other BrightLine panels, or combine with WaveLine and SharpLine displays, to create unique branded environments. TV mounts and counters complete an enhanced experience to really make brands stand out.</p>	

KEY FEATURES	
<ul style="list-style-type: none"> • Easy tool free assembly • Lightweight portable construction • Magnetic power links • LED lights encapsulated in frame 	<ul style="list-style-type: none"> • Heavy duty shipping case, molded foam inserts • Single- or double-sided • Vibrant graphics on recycled fabric

DISPLAY CONSTRUCTION
Aluminum frame with aluminum support poles

DIMENSIONS	
Assembled Unit	40"w x 89"h x 4"d
Packed Case	46.5"w x 15"h x 8.7"d, 43 lbs
Shipping Box	47"w x 16"h x 10"d, 45 lbs
Graphic Size	40"w x 89"h

GRAPHIC MATERIAL	
Graphic Print : Dye sublimated on One Planet, 100% recycled, backlit fabric	Bottles recycled 26
Blocker : One Planet light block recycled fabric	Bottles recycled 10

LED LIGHT SPECIFICATIONS	
Power Requirements	64 W
CCT (Color Temp)	6000 K
Voltage Input	110 / 220V
Voltage Output	24V 4A 96W
Transformers Included	1

GRAPHIC FINISHING
Silicone sewn edges

WARRANTY
Limited Warranty Periods
- Frame : Lifetime
- Lights : 90 days
- Graphics : 30 days

PARTS

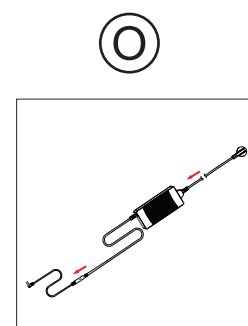
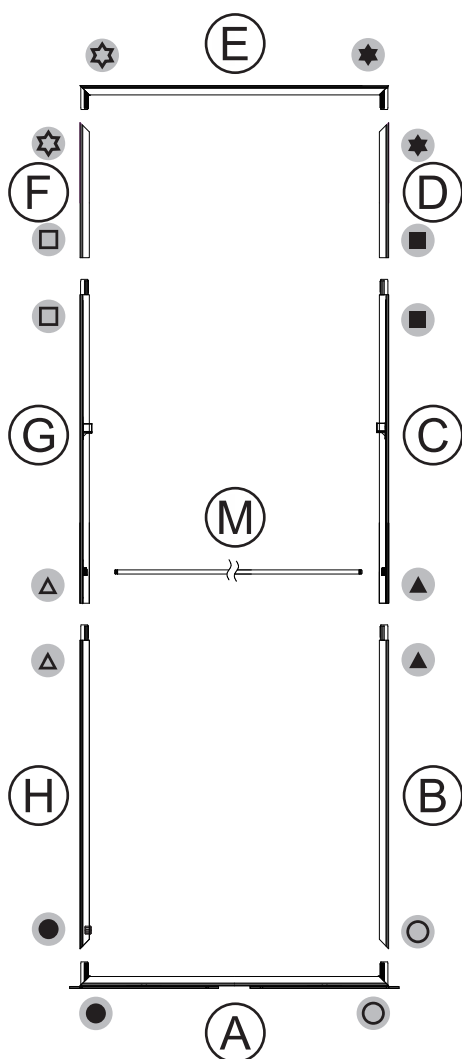
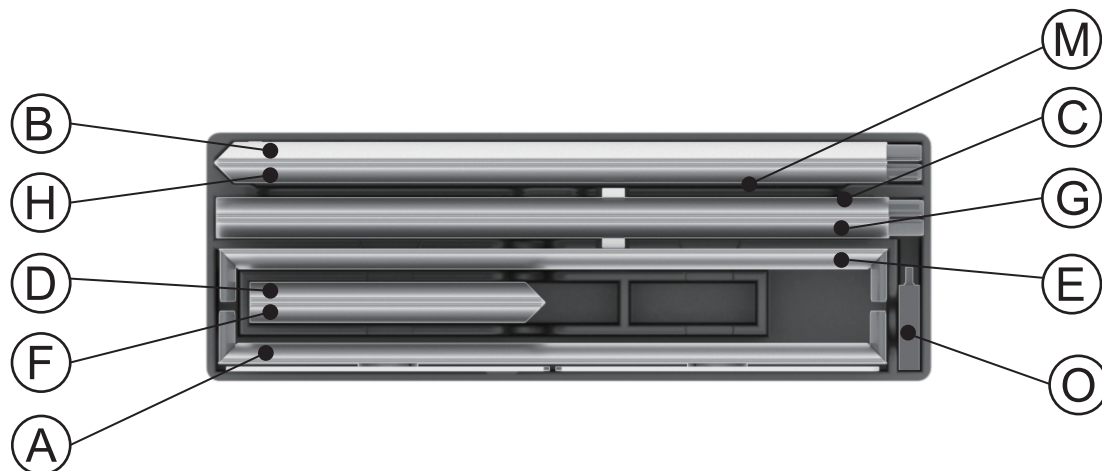

ASSEMBLY

Assemble parts on the floor and stand-up unit when completed.

1

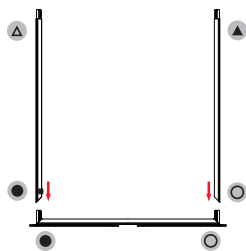
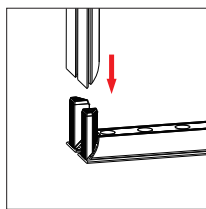

3

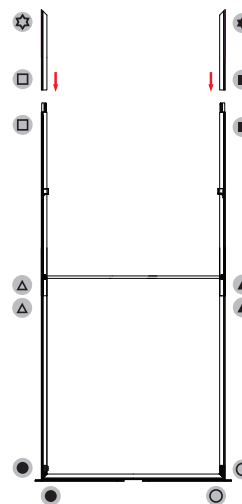
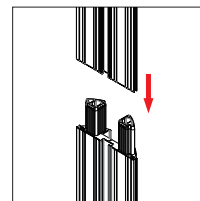

2

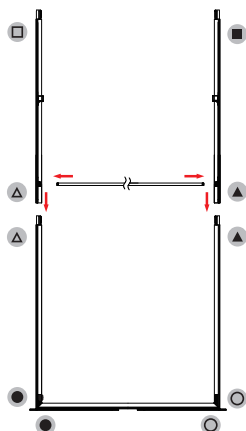
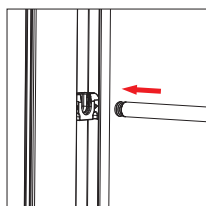

4

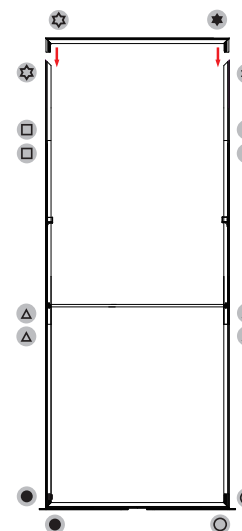
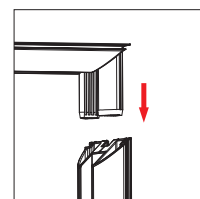

5 Push the silicone bead into each corner of the frame with your thumb.

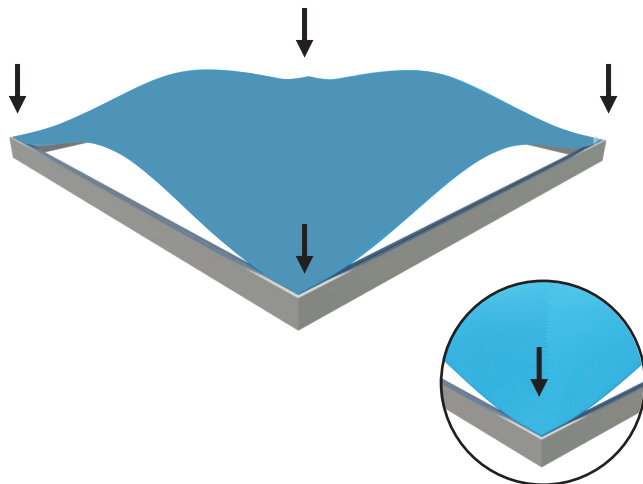

Push the silicone bead into the middle of the run and work your way around the perimeter of the frame until all beading is pushed in properly

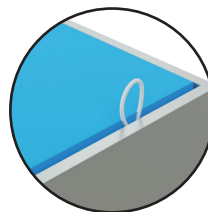
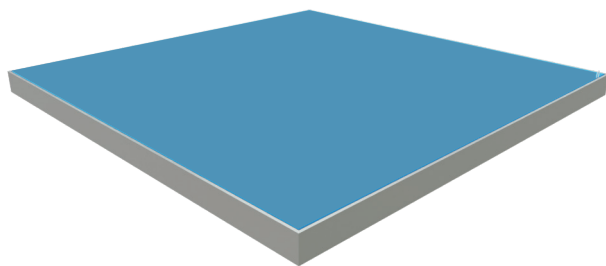
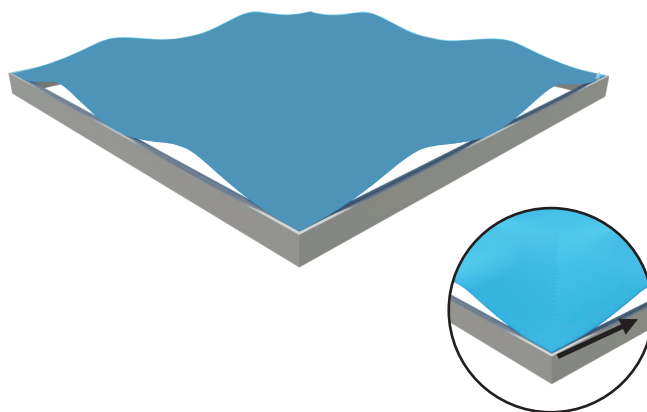

To Remove Graphic
Use the pull tab located on the graphic and gently pull the graphic from the frame, going around the perimeter

6

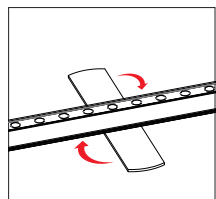
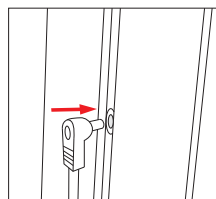

Monitor Mount

BLM-TV-40-K

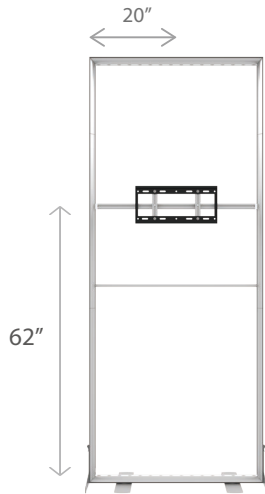

PRODUCT DESCRIPTION

Designed for compatibility with BrightLine and StraightLine Displays, these mounts deliver a captivating “floating” screen sensation. Simply slide the TV bar into the frame, secure the monitor plate with screws, and attach your screen on the front. Side feet are included in the kit for extra stability. Graphics can be finished with four small pre-cut slits for convenient access, or you can customize your own cutouts as required.





MONITOR SPECIFICATIONS

Holds monitors up to 25 lbs, VESA 200 X 200

DIMENSIONS

Shipping Box	14" w x 4" d x 42" h, 10 lbs
--------------	------------------------------

PARTS

(1x) Allen Key	 5mm
(4x) Bracket-to-Monitor Screws: M5, M6, & M8 screws included. Check your TV for specs	
Spacers	
Cutter	

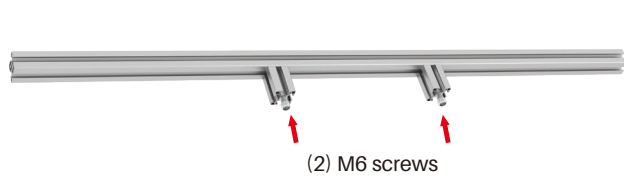
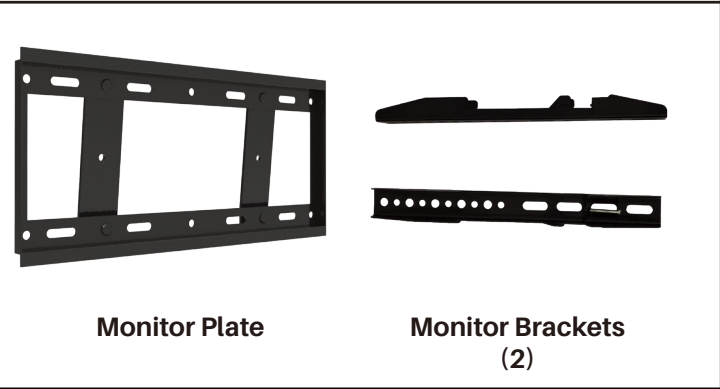

TV Bar 40"

Side Foot (2)

*Philips Screwdriver not included

Monitor Mount

BLM-TV-40-K

BrightLine®

StraightLine®

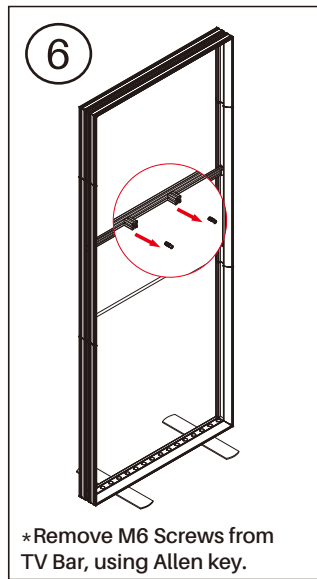
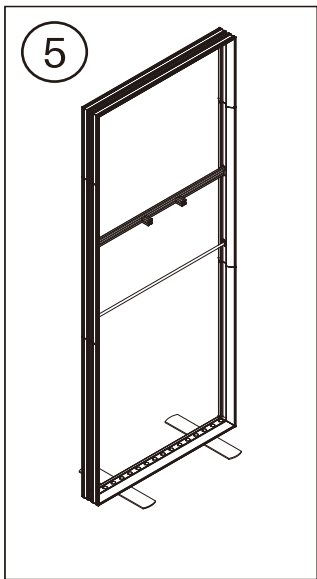
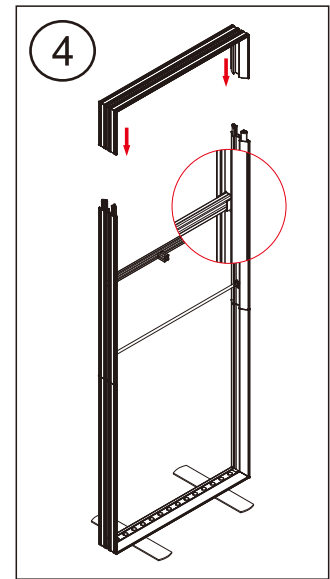
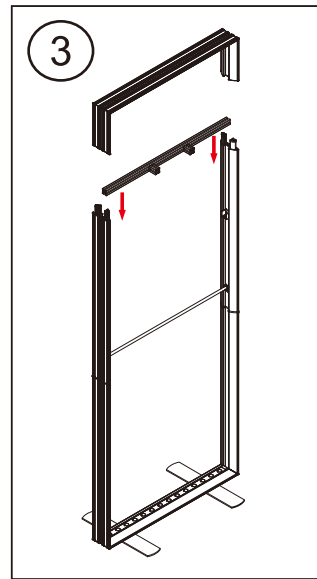
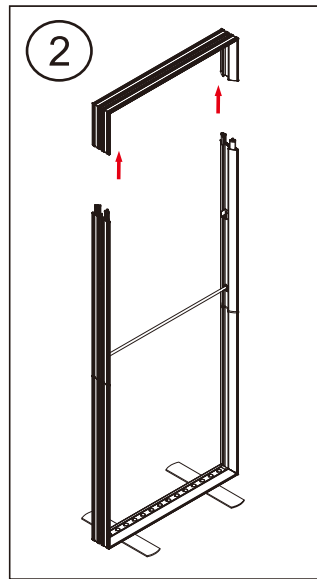

*Remove M6 Screws from TV Bar, using Allen key.

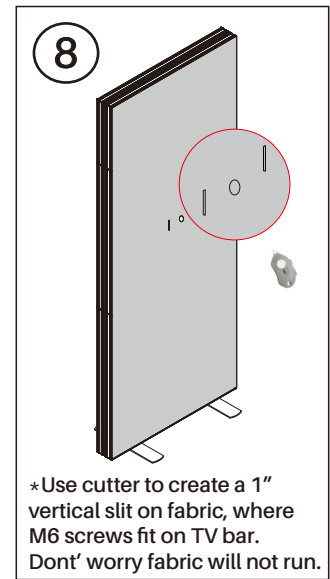
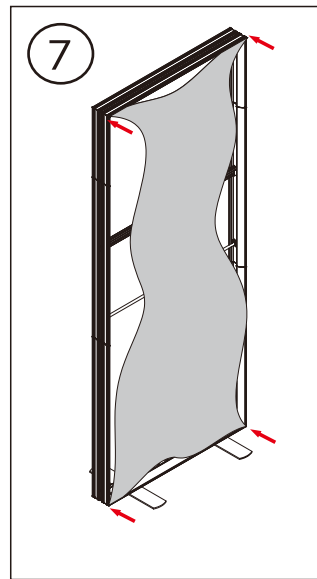

*Use cutter to create a 1" vertical slit on fabric, where M6 screws fit on TV bar. Don't worry fabric will not run.

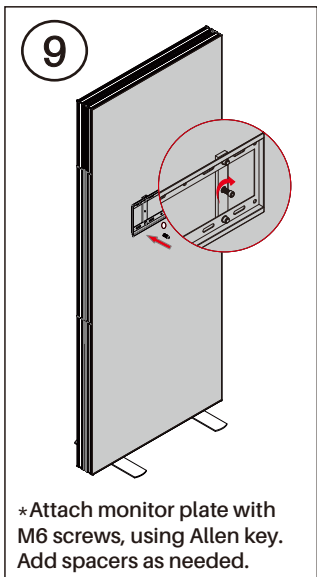

*Attach monitor plate with M6 screws, using Allen key. Add spacers as needed.

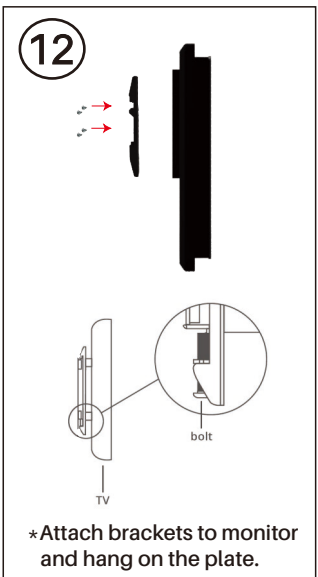
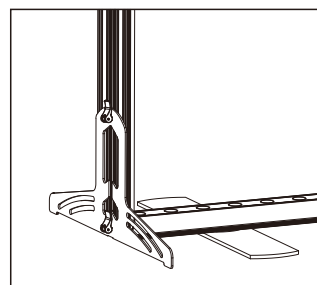
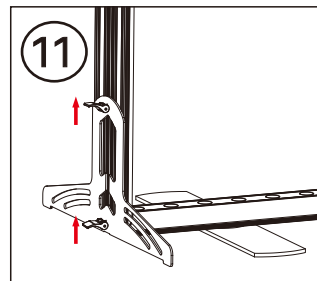
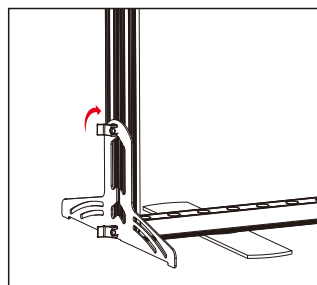
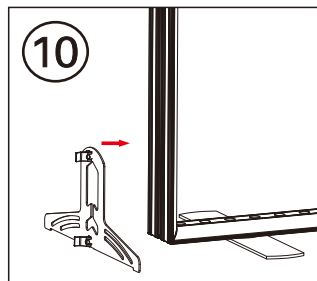

*Attach brackets to monitor and hang on the plate.

PARTS INCLUDED

Adhesive Cable Clips (4x)



Reusable Velcro Cable Ties (5x)



Resealable Lock Bag



You will need 10ft Extension Cable

1

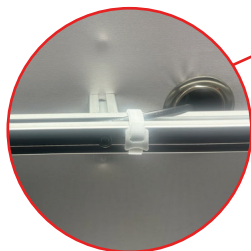

Connect the extension cable to your TV. Route cable inside the groove of the TV bar and use cable ties to secure in place.

2

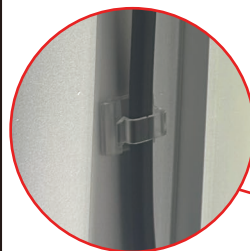

Attach wire clips to the frame. Then route the cable through and secure within the clips.

3



Route cable through the bottom corner of the frame.

4

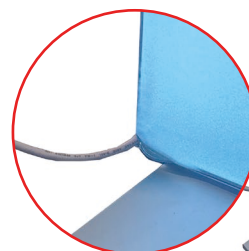

Secure the vertical end of the graphic first, adjust cable, then finish with the bottom of the fabric

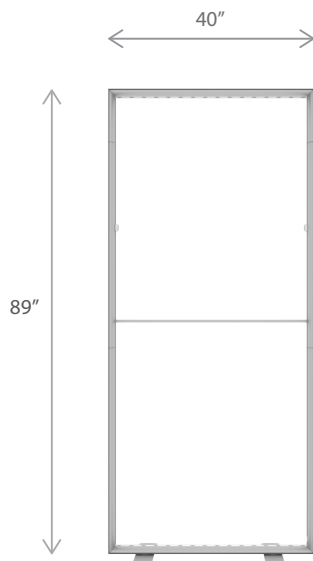

PRODUCT DESCRIPTION	
<p>BrightLine smart light box displays feature swift tool-free installation, durable light-weight frames, embedded LEDs, and exclusive One Planet recycled fabrics with impressive vivid graphics, all conveniently organized in a heavy-duty shipping case. Panel D is sized for versatile applications, as a stand-alone banner or combined to create popular 10 foot and 20ft exhibits.</p> <p>Mix-and-match with other BrightLine panels, or combine with WaveLine and SharpLine displays, to create unique branded environments. TV mounts and counters complete an enhanced experience to really make brands stand out.</p>	

KEY FEATURES	
<ul style="list-style-type: none"> • Easy tool free assembly • Lightweight portable construction • Magnetic power links • LED lights encapsulated in frame 	<ul style="list-style-type: none"> • Heavy duty shipping case, molded foam inserts • Single- or double-sided • Vibrant graphics on recycled fabric

DISPLAY CONSTRUCTION
Aluminum frame with aluminum support poles

DIMENSIONS	
Assembled Unit	40"w x 89"h x 4"d
Packed Case	46.5"w x 15"h x 8.7"d, 43 lbs
Shipping Box	47"w x 16"h x 10"d, 45 lbs
Graphic Size	40"w x 89"h

GRAPHIC MATERIAL	
Graphic Print : Dye sublimated on One Planet, 100% recycled, backlit fabric	Bottles recycled 26
Blocker : One Planet light block recycled fabric	Bottles recycled 10

LED LIGHT SPECIFICATIONS	
Power Requirements	64 W
CCT (Color Temp)	6000 K
Voltage Input	110 / 220V
Voltage Output	24V 4A 96W
Transformers Included	1

GRAPHIC FINISHING
Silicone sewn edges

WARRANTY
Limited Warranty Periods
- Frame : Lifetime
- Lights : 90 days
- Graphics : 30 days

PARTS

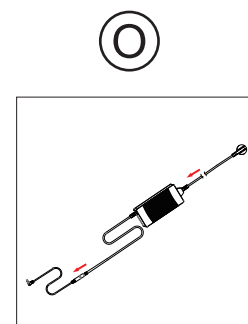
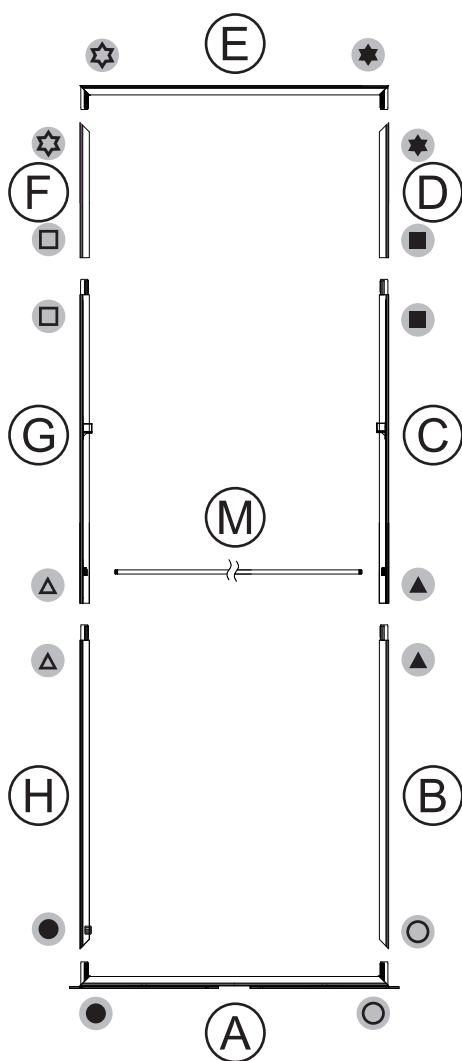
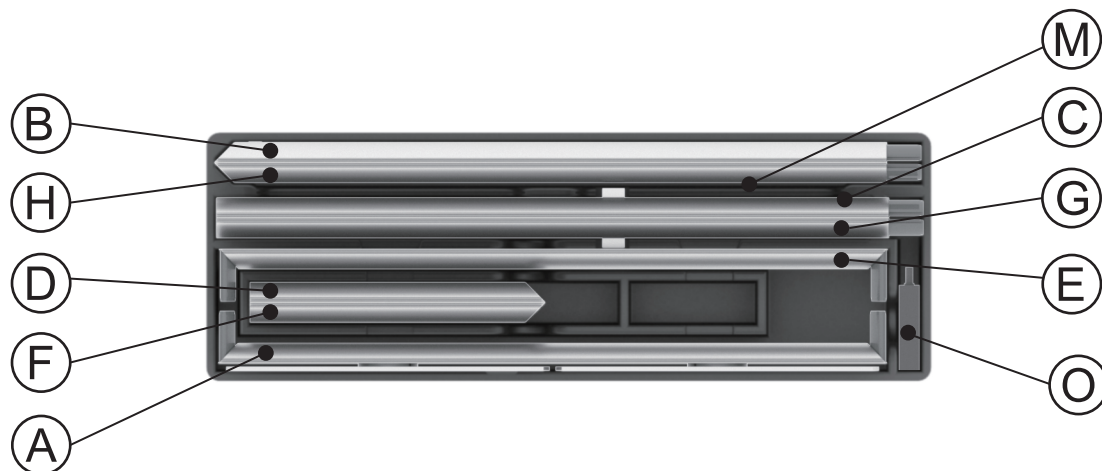

ASSEMBLY

Assemble parts on the floor and stand-up unit when completed.

1

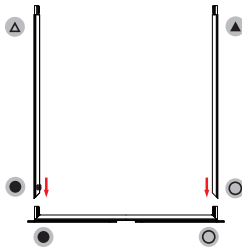
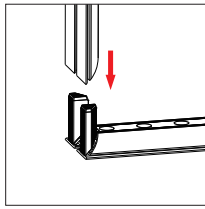

3

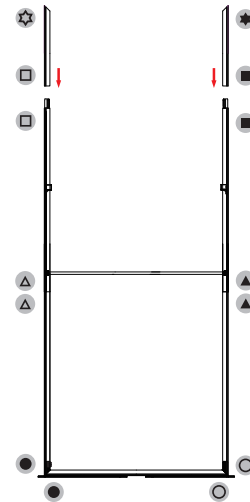
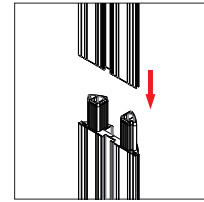

2

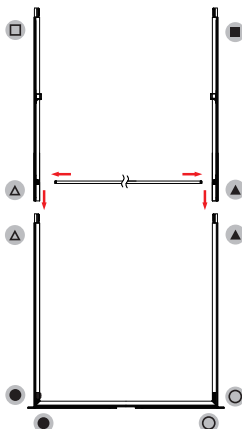
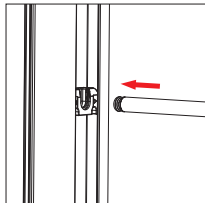

4

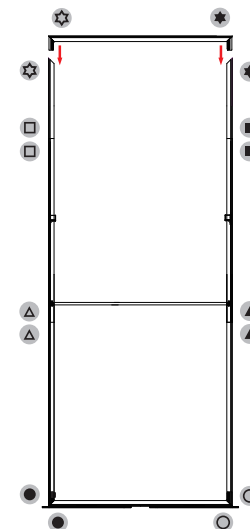
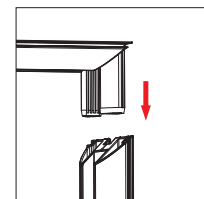

5 Push the silicone bead into each corner of the frame with your thumb.

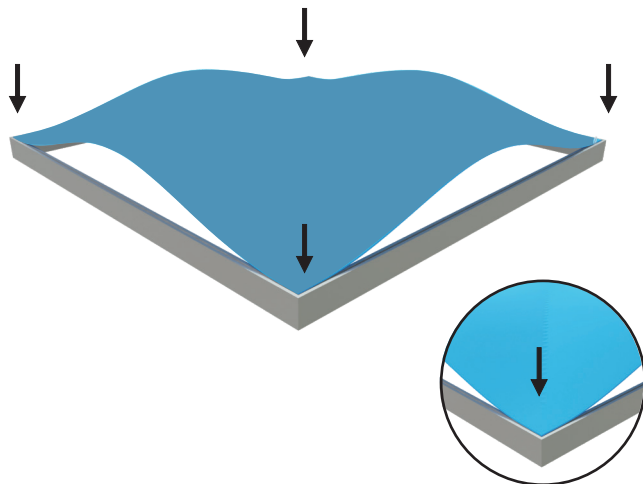

Push the silicone bead into the middle of the run and work your way around the perimeter of the frame until all beading is pushed in properly

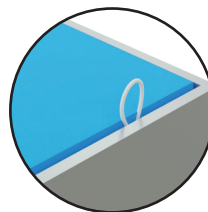
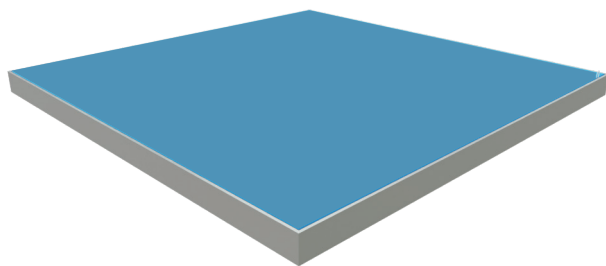
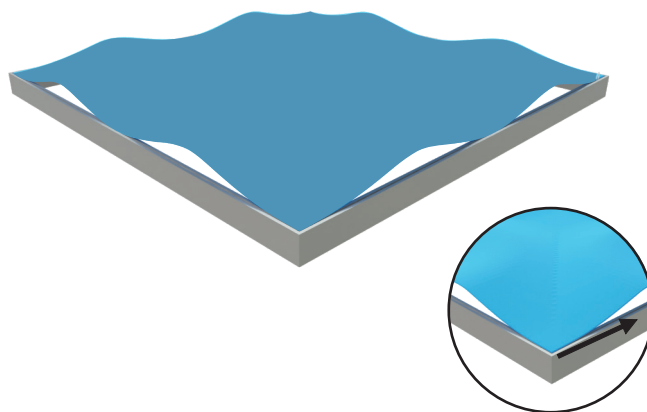

To Remove Graphic
Use the pull tab located on the graphic and gently pull the graphic from the frame, going around the perimeter

6

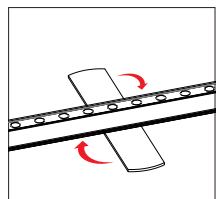
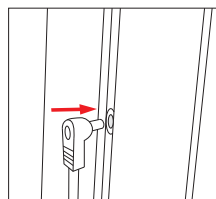

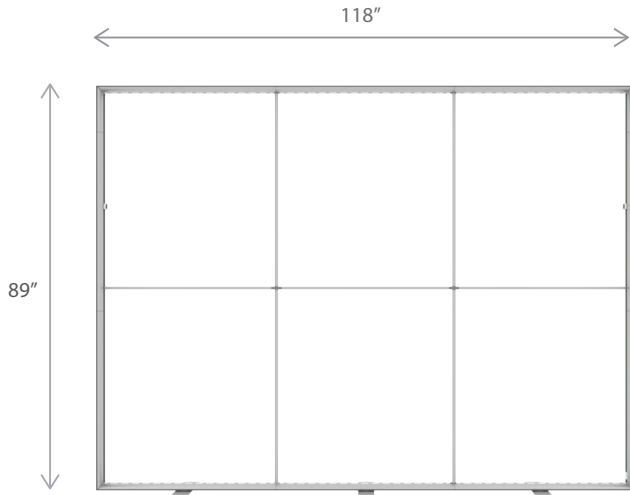

PRODUCT DESCRIPTION

BrightLine smart light box displays feature swift tool-free installation, durable light-weight frames, embedded LEDs, and exclusive One Planet recycled fabrics with impressive vivid graphics, all conveniently organized in a heavy-duty shipping case. Panel F seamlessly fills the popular 10ft exhibit, providing an illuminated backdrop for elevated branding.

Mix-and-match with other BrightLine panels, or combine with WaveLine and SharpLine displays, to create unique branded environments. TV mounts and counters complete an enhanced experience to really make brands stand out.

KEY FEATURES

- Easy tool free assembly
- Lightweight portable construction
- Magnetic power links
- LED lights encapsulated in frame
- Heavy duty shipping case, molded foam inserts
- Single- or double-sided
- Vibrant graphics on recycled fabric

DISPLAY CONSTRUCTION

Aluminum frame with aluminum support poles

DIMENSIONS

Assembled Unit	118" w x 89" h x 4" d
Packed Case	46.5" w x 15" h x 12" d, 70 lbs
Shipping Box	47" w x 16" h x 13" d, 72 lbs
Graphic Size	118" w x 89" h

GRAPHIC MATERIAL

Graphic Print : Dye sublimated on One Planet, 100% recycled, backlit fabric	Bottles recycled 76
Blocker : One Planet light block recycled fabric	Bottles recycled 30

LED LIGHT SPECIFICATIONS

Power Requirements	192 W
CCT (Color Temp)	6000 K
Voltage Input	110 / 220V
Voltage Output	24V 11A 264W
Transformers Included	1

GRAPHIC FINISHING

Silicone sewn edges

WARRANTY

Limited Warranty Periods

- Frame : Lifetime
- Lights : 90 days
- Graphics : 30 days

PARTS

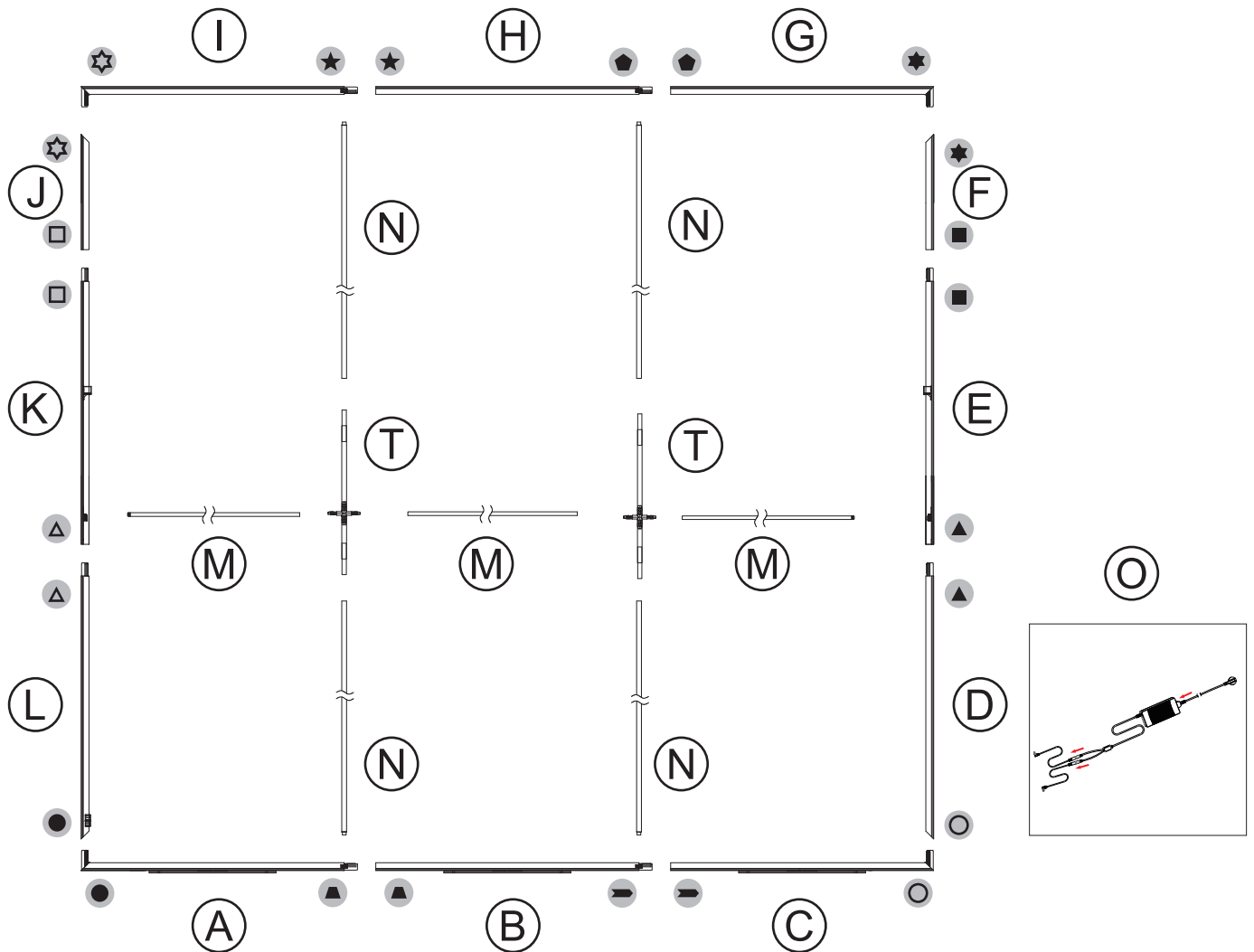
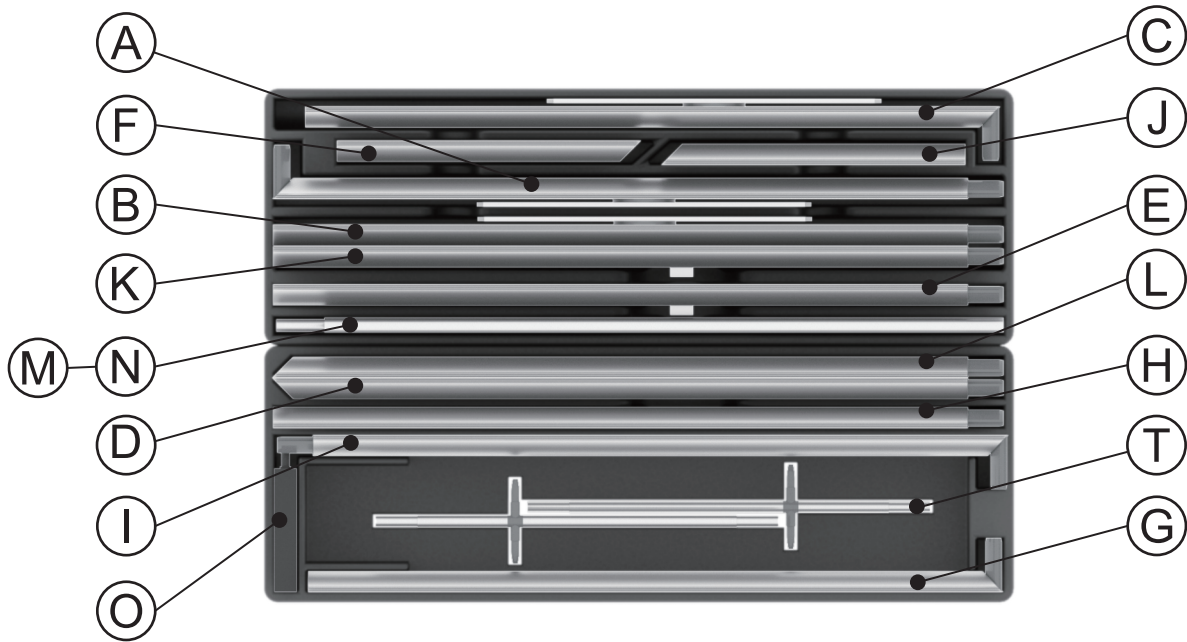

ASSEMBLY

Assemble parts on the floor and stand-up unit when completed.

1

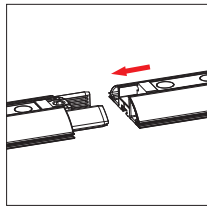

2

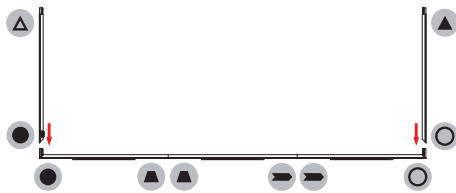
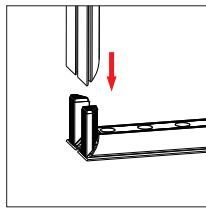

3

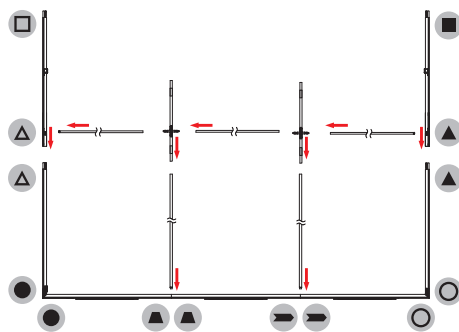
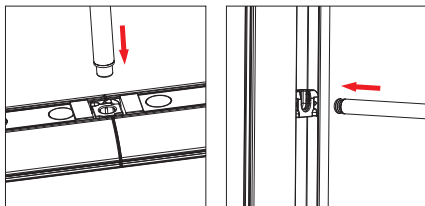

4

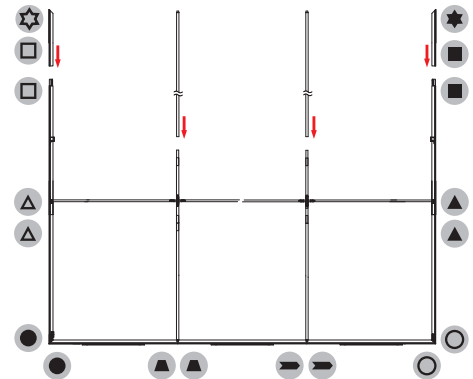
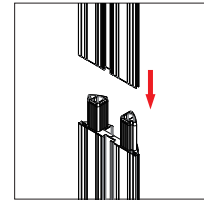

5

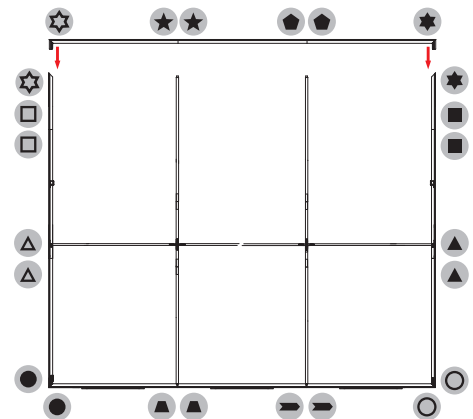
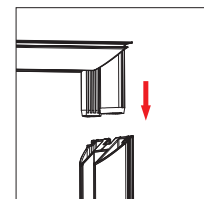

6 Push the silicone bead into each corner of the frame with your thumb.

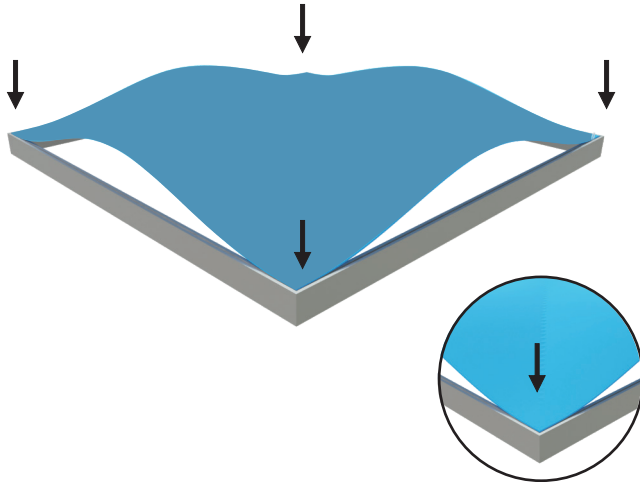

Push the silicone bead into the middle of the run and work your way around the perimeter of the frame until all beading is pushed in properly

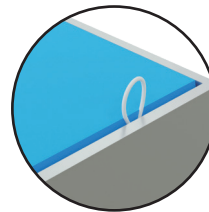
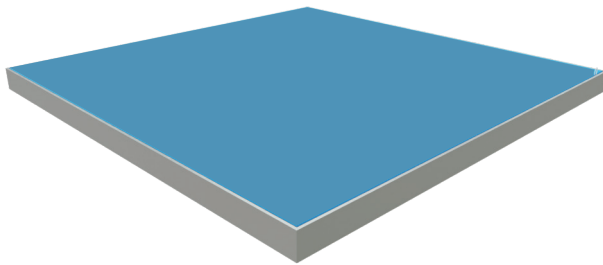
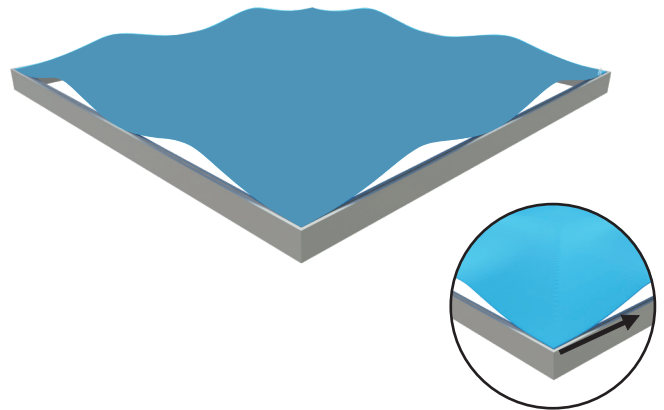

To Remove Graphic
Use the pull tab located on the graphic and gently pull the graphic from the frame, going around the perimeter

7

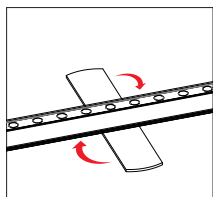
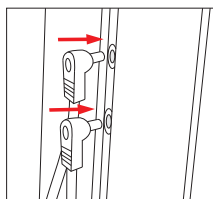

1 *Align frames at 90°

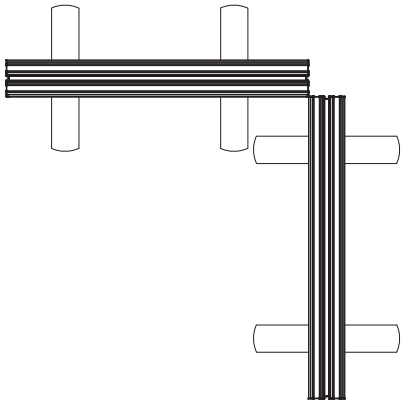

2 *Insert connector into channel

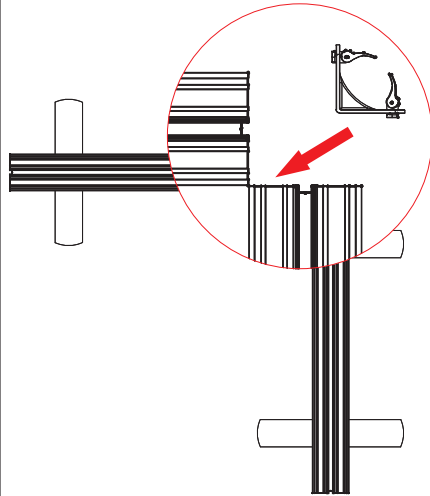

3 *Turn

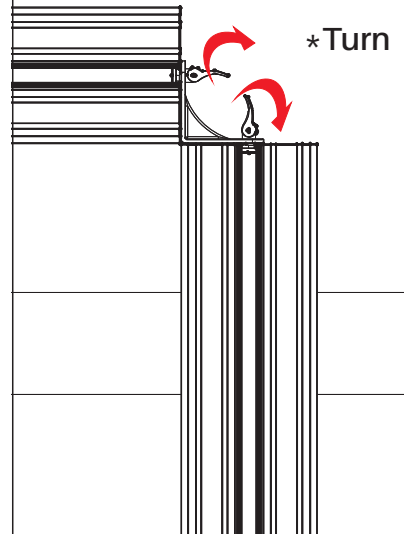

4 *Push down

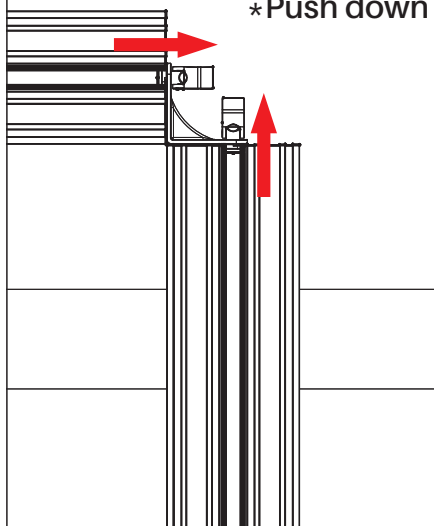

5 *Closed view

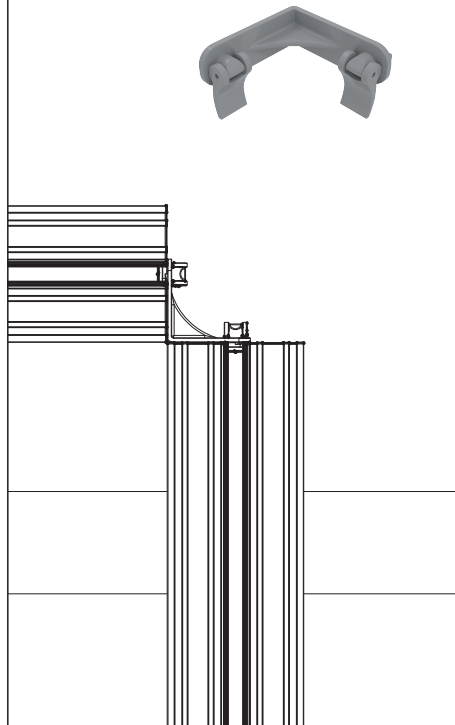

6

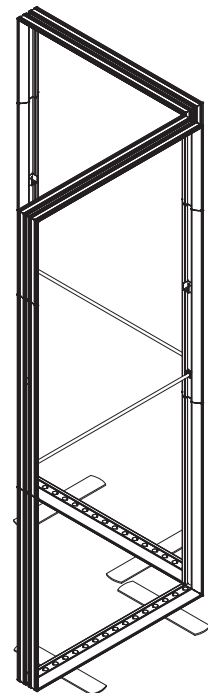

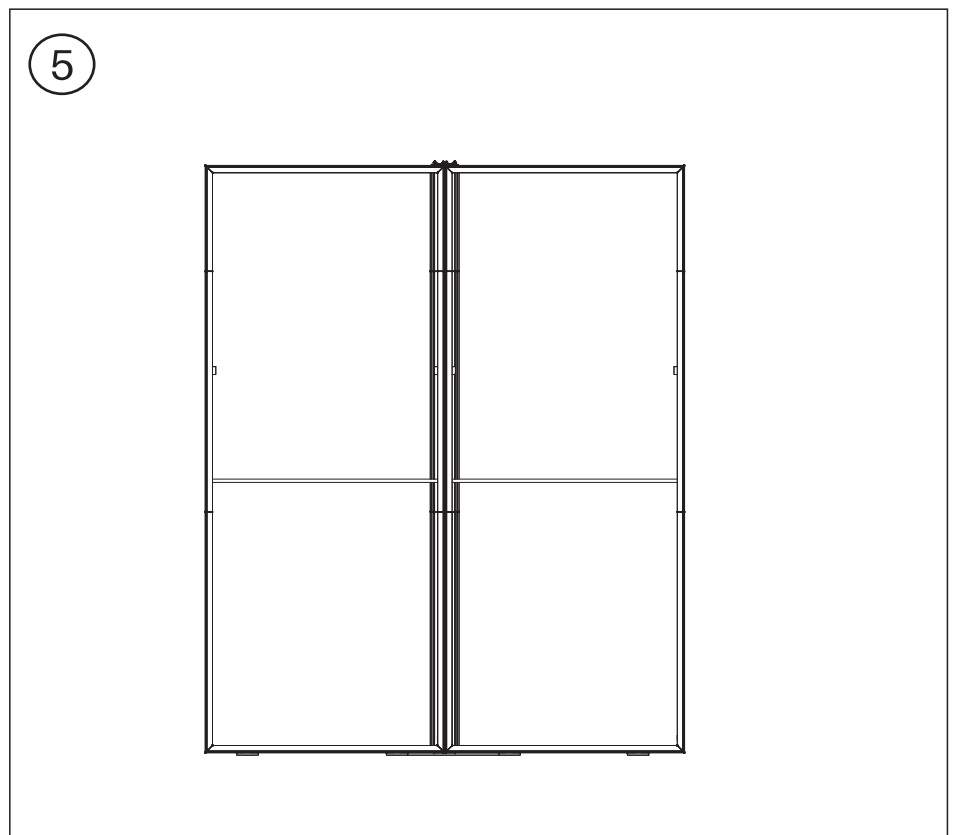
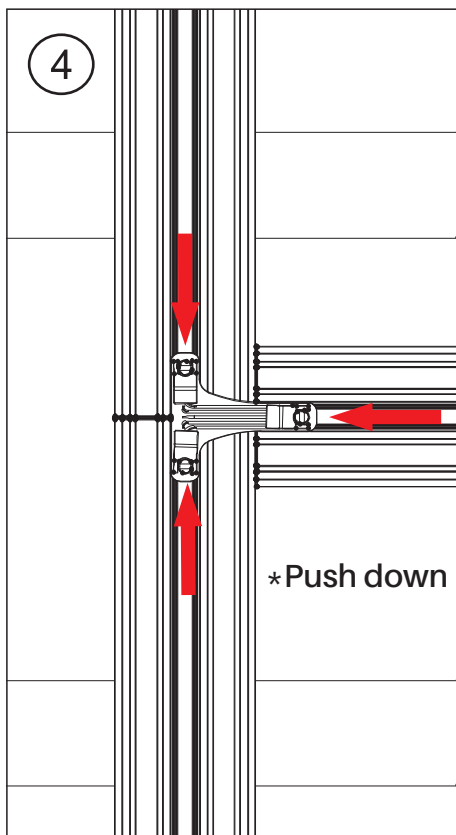
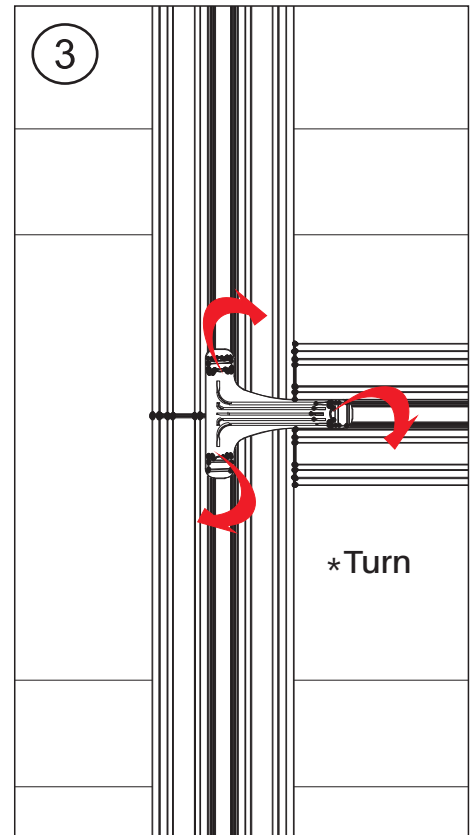
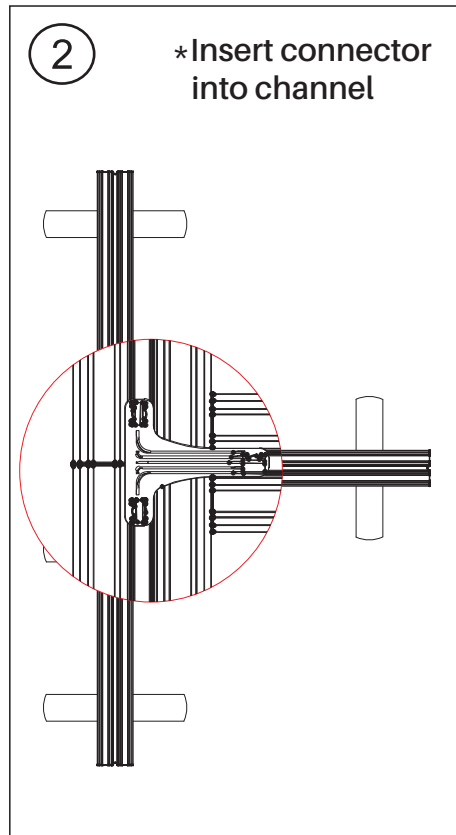
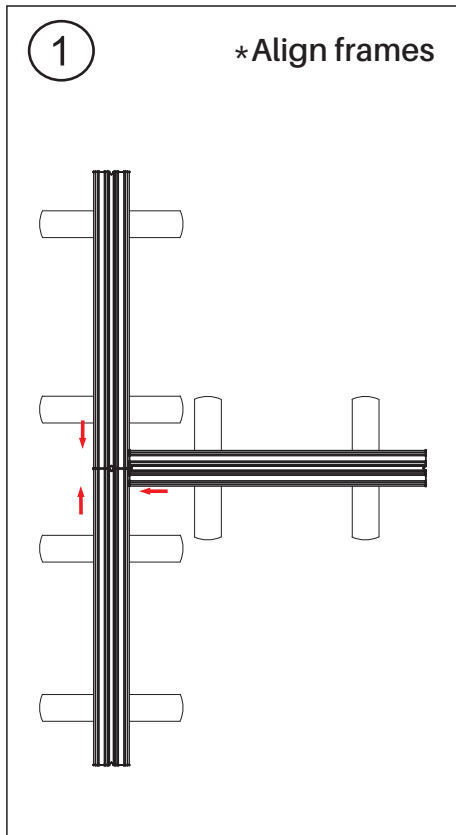

PARTS

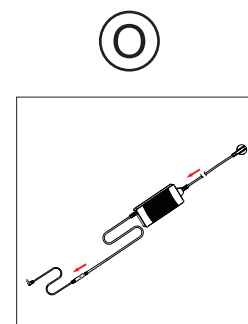
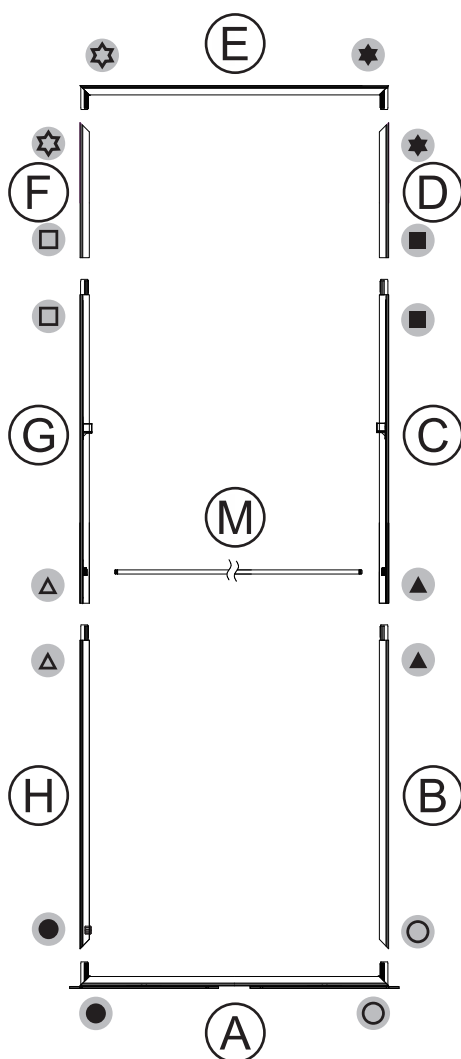
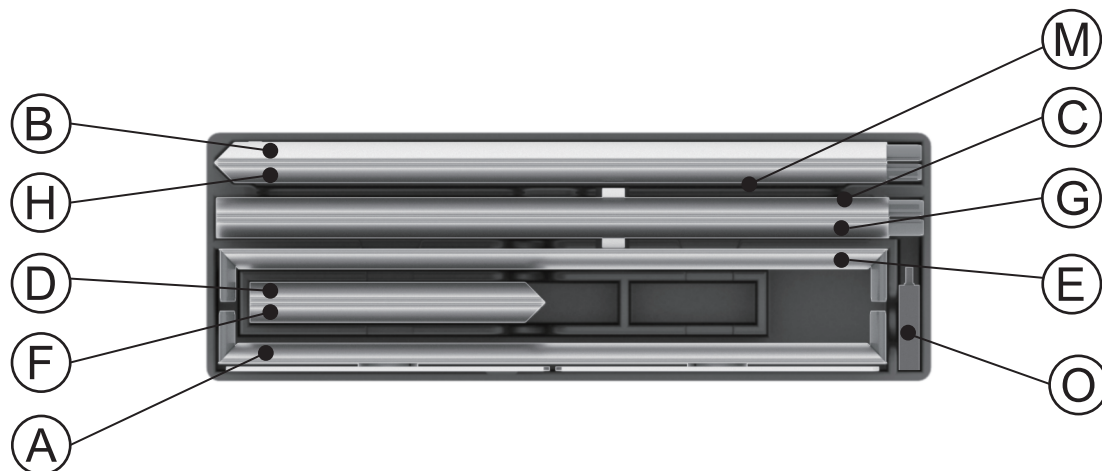

PARTS

