

COMPONENTS		
(K) Panel K		2x
(J) Panel J		2x
(H) 10ft Hanging Sign		1x
(C) Counter		2x
(WF) 36" XL Waterfall		2x
(WS) Waterfall Shelves		6x
(WB) WLM to BLM 90		2x
(C-T) Connector T		4x
(K-TV) BLM-TV-60		2x

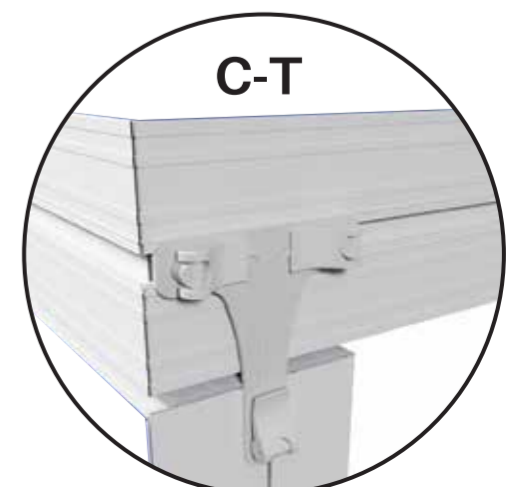

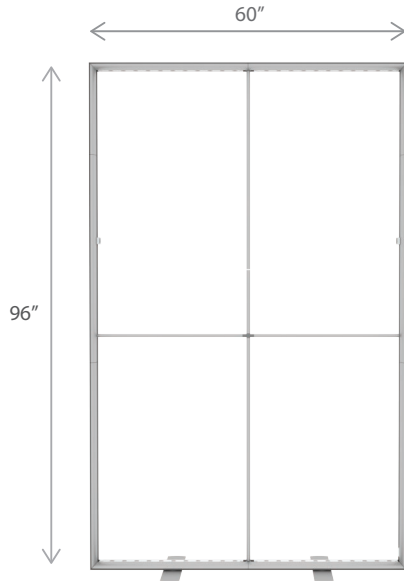

PRODUCT DESCRIPTION

BrightLine smart light box displays feature swift tool-free installation, durable light-weight frames, embedded LEDs, and exclusive One Planet recycled fabrics with impressive vivid graphics, all conveniently organized in a heavy-duty shipping case. Panel K is the taller variant of the highly sought 5ft light box, which allows for alluring impact on its own, as well as versatile pairings in larger exhibits.

Mix-and-match with other BrightLine panels, or combine with WaveLine and StraightLine displays, to create unique branded environments. TV mounts and counters complete an enhanced experience to really make brands stand out.

KEY FEATURES

- Easy tool free assembly
- Lightweight portable construction
- Magnetic power links
- LED lights encapsulated in frame
- Heavy duty shipping case, molded foam inserts
- Single- or double-sided
- Vibrant graphics on recycled fabric

DISPLAY CONSTRUCTION

Aluminum frame with aluminum support poles

DIMENSIONS

Assembled Unit	60"w x 96"h x 4"d
Packed Case	46.5"w x 15"h x 12"d, 53 lbs
Shipping Box	47"w x 16"h x 13"d, 55 lbs
Graphic Size	60"w x 96"h

GRAPHIC MATERIAL

Graphic Print : Dye sublimated on One Planet, 100% recycled, backlit fabric	Bottles recycled 42
Blocker : One Planet light block recycled fabric	Bottles recycled 17

LED LIGHT SPECIFICATIONS

Power Requirements	112 W
CCT (Color Temp)	6000 K
Voltage Input	110 / 220V
Voltage Output	24V 11A 264W
Transformers Included	1

GRAPHIC FINISHING

Silicone sewn edges

WARRANTY

Limited Warranty Periods

- Frame : Lifetime
- Lights : 90 days
- Graphics : 30 days

PARTS

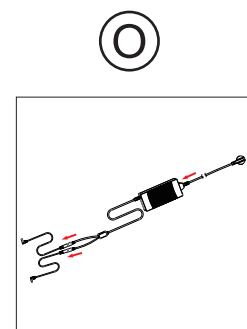
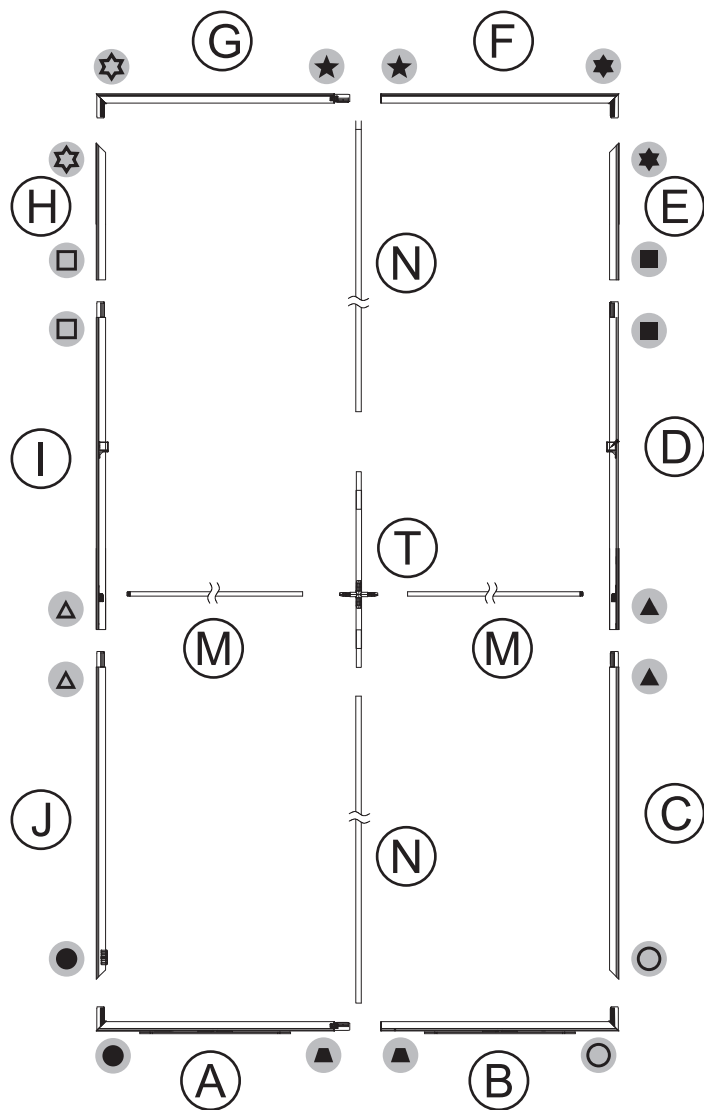
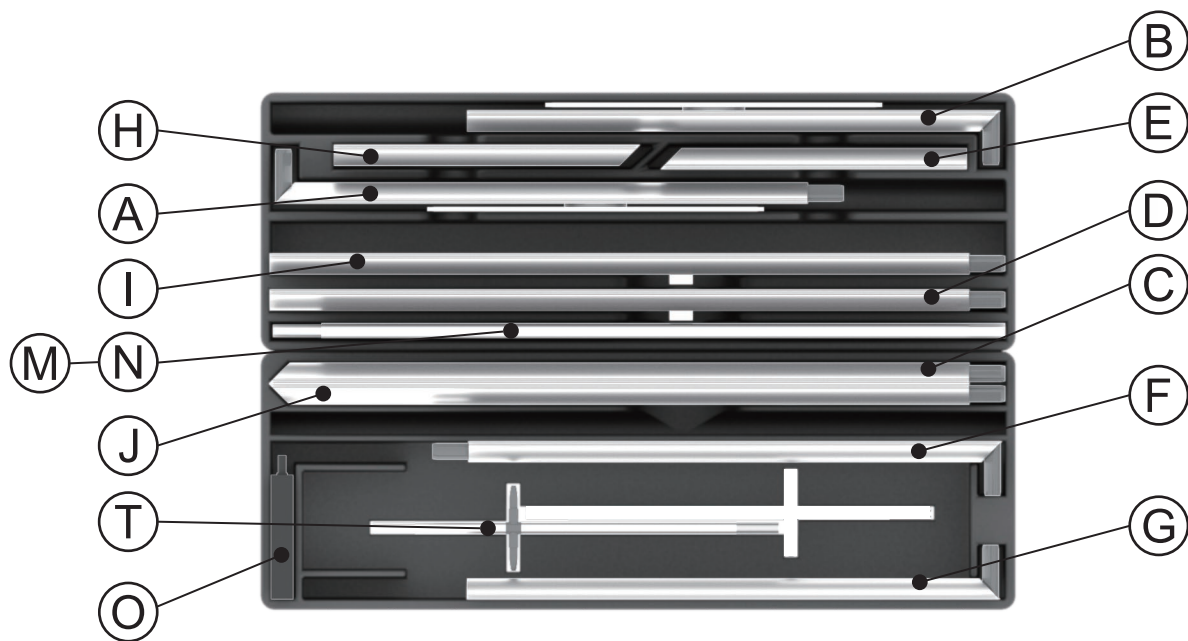

ASSEMBLY

Assemble parts on the floor and stand-up unit when completed.

1

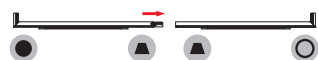
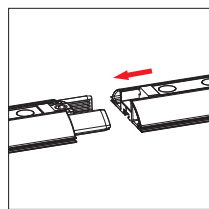

2

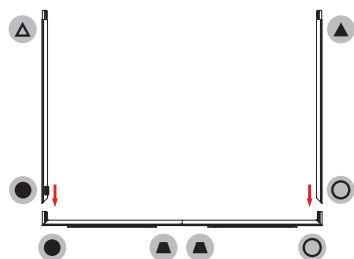
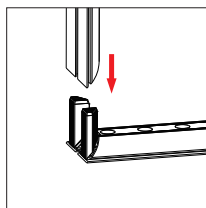

3

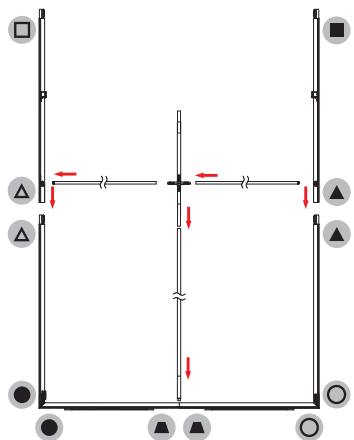
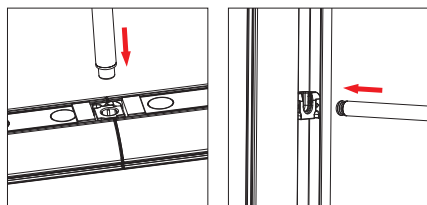

4

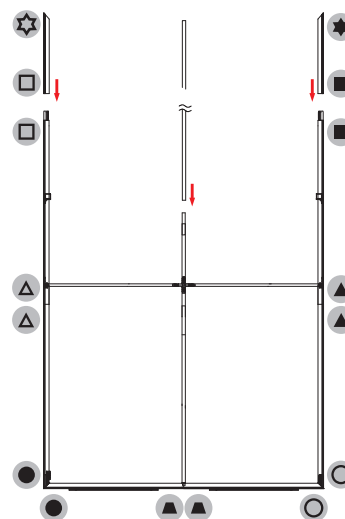
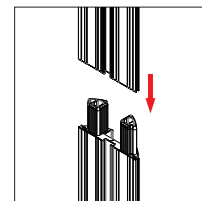

5

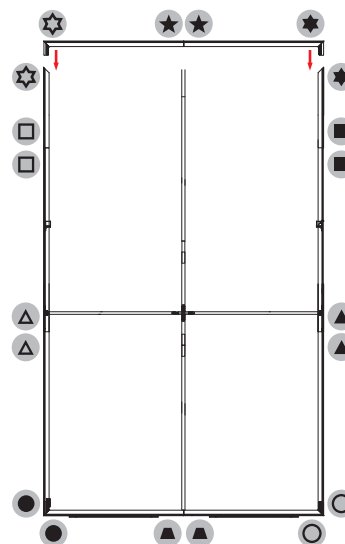
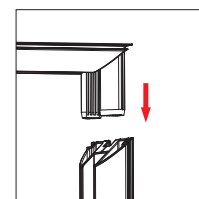

6 Push the silicone bead into each corner of the frame with your thumb.

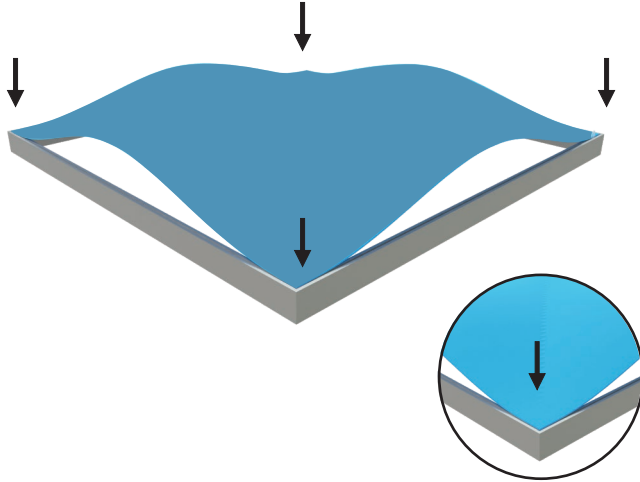

Push the silicone bead into the middle of the run and work your way around the perimeter of the frame until all beading is pushed in properly

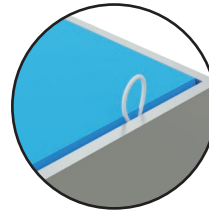
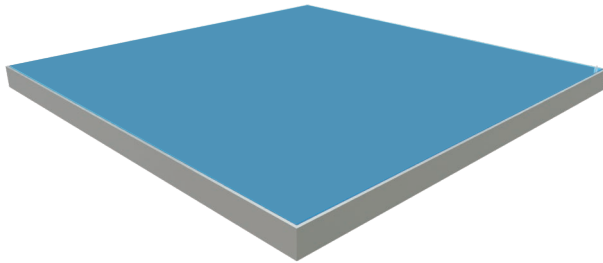
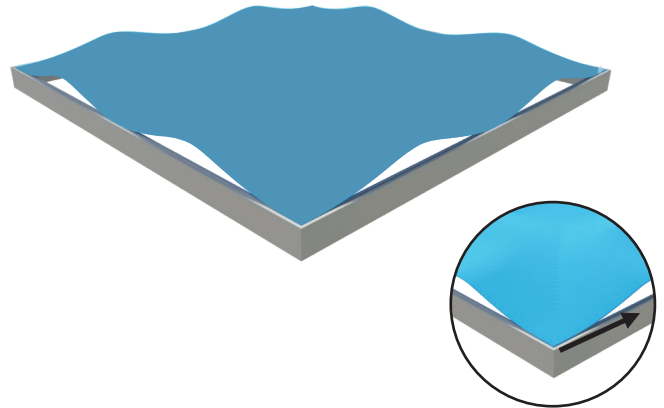

To Remove Graphic
Use the pull tab located on the graphic and gently pull the graphic from the frame, going around the perimeter

7

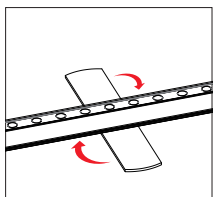
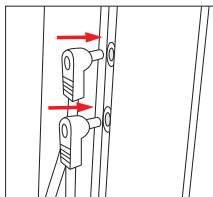

Monitor Mount

BLM-TV-60-K

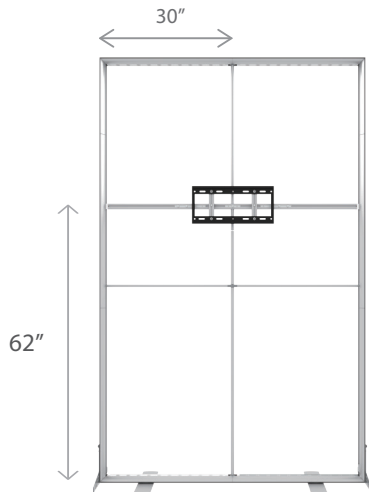

PRODUCT DESCRIPTION

Designed for compatibility with BrightLine and StraightLine Displays, these mounts deliver a captivating “floating” screen sensation. Simply slide the TV bar into the frame, secure the monitor plate with screws, and attach your screen on the front. Side feet are included in the kit for extra stability. Graphics can be finished with four small pre-cut slits for convenient access, or you can customize your own cutouts as required.

MONITOR SPECIFICATIONS

Holds monitors up to 25 lbs, VESA 200 X 200

DIMENSIONS

Shipping Box	14" w x 4" d x 42" h, 13 lbs
--------------	------------------------------

PARTS

(1x) Allen Key	5mm
(4x) Bracket-to-Monitor Screws: M5, M6, & M8 screws included. Check your TV for specs	
Spacers	
Cutter	

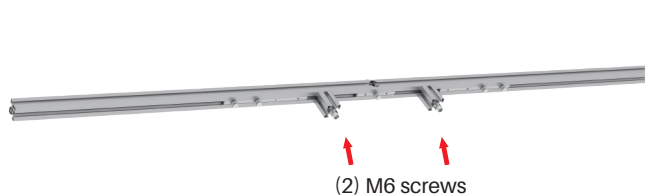
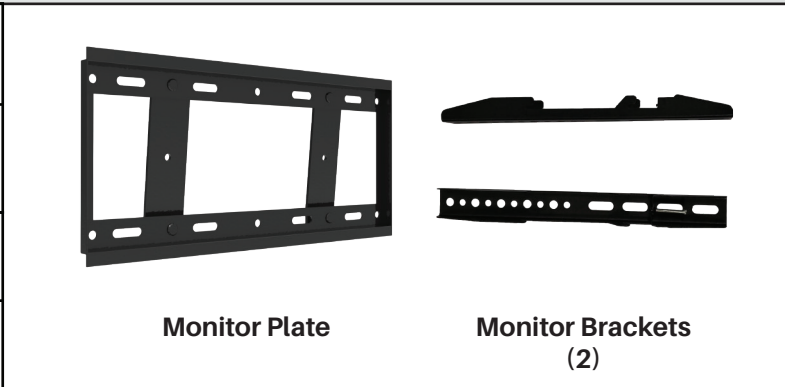

TV Bar 60"

Side Foot (2)

*Philips Screwdriver not included

Monitor Mount

BLM-TV-60-K

BrightLine

StraightLine

1

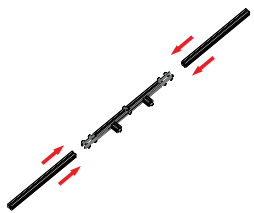

* Tighten screws to secure bar together.

2

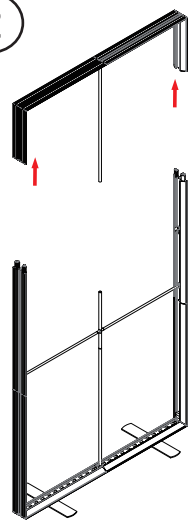

* Loosen screws to insert center pole.

3

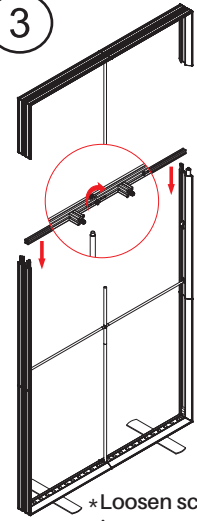

* Loosen screws to insert center pole.

4

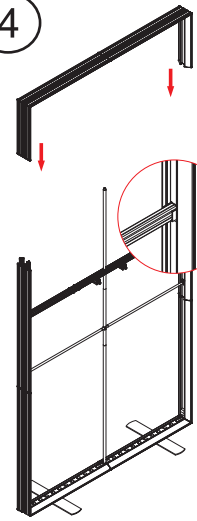

5

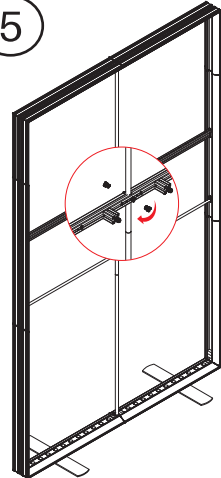

* Tighten screws to pole.

6

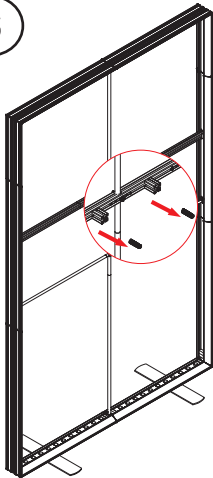

* Remove M6 Screws from TV Bar, using Allen key.

7

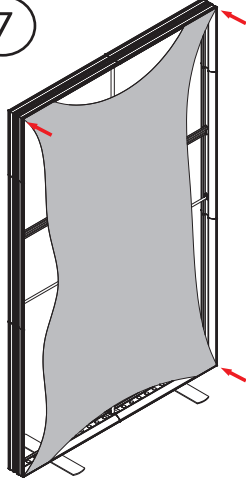

8

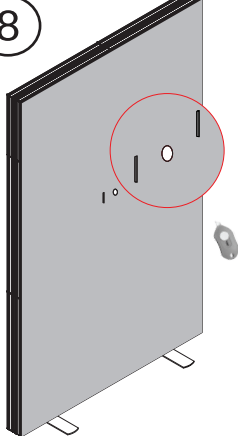

* Use cutter to create a 1" vertical slit on fabric, where M6 screws fit on TV bar. Don't worry fabric will not run.

9

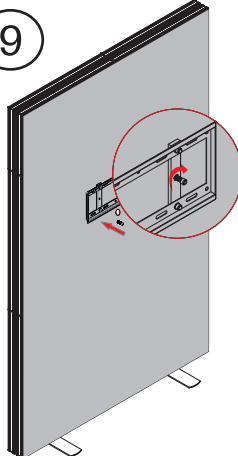

* Attach monitor plate with M6 screws, using Allen key. Add spacers as needed.

10

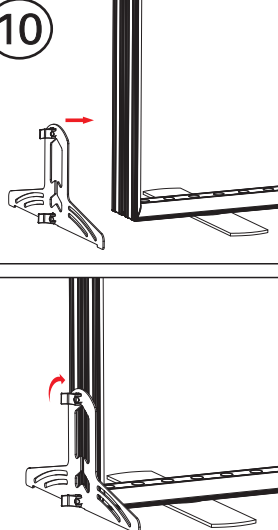

11

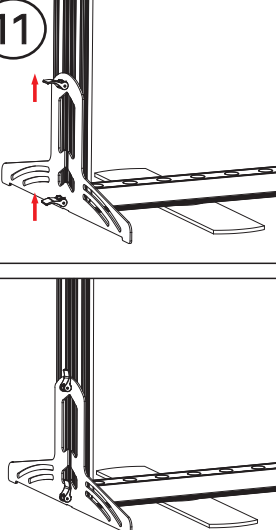

12

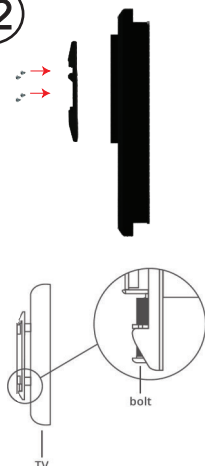

* Attach brackets to monitor and hang on the plate.

PARTS INCLUDED

Adhesive Cable Clips (4x)



Reusable Velcro Cable Ties (5x)



Resealable Lock Bag



You will need 10ft Extension Cable

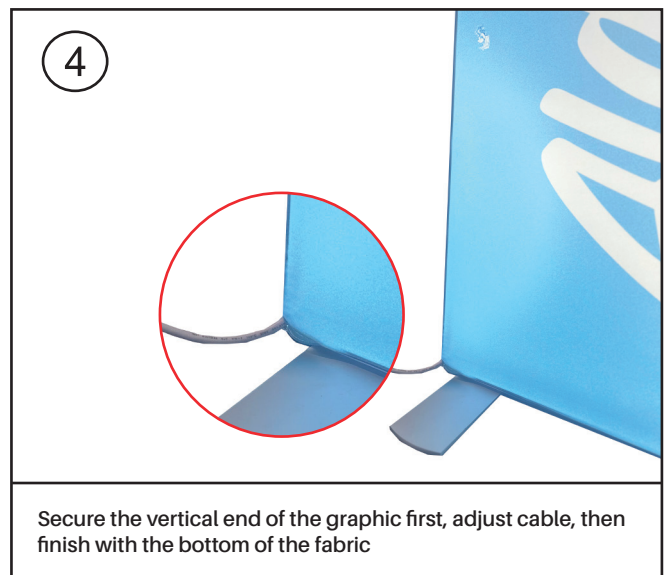
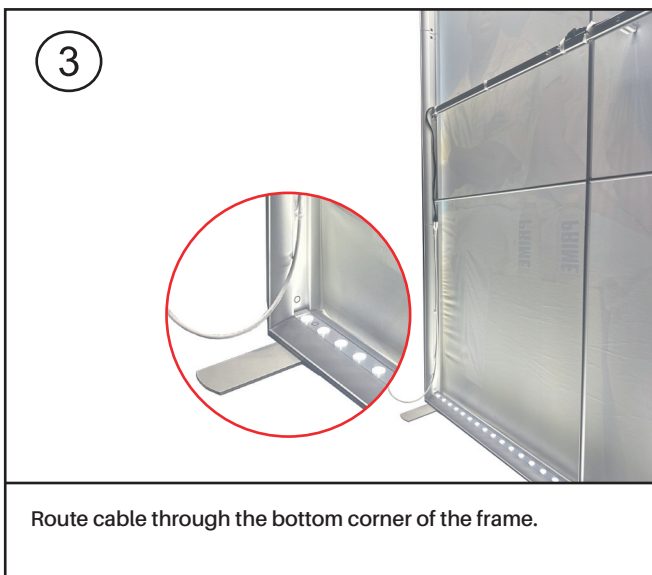
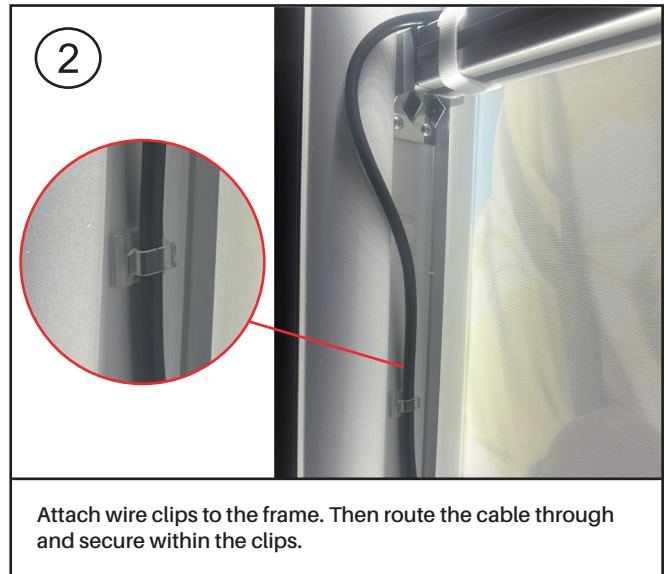
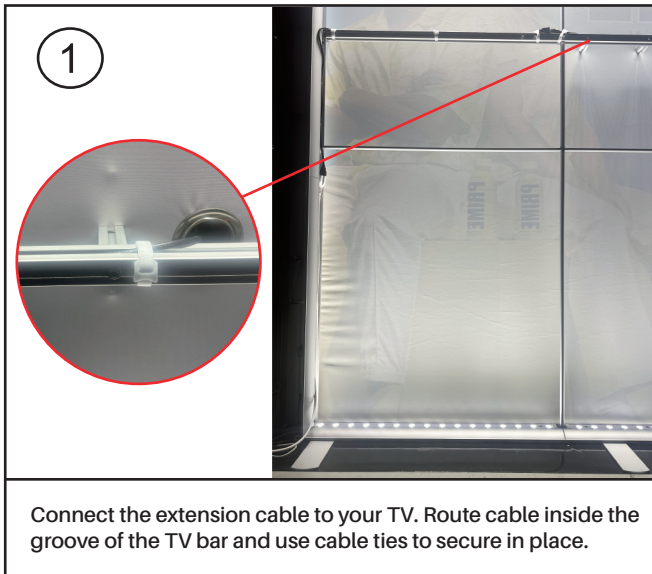

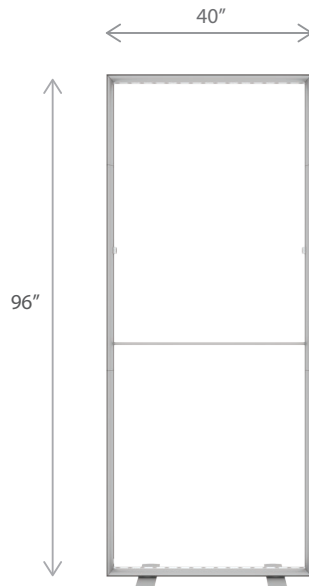

PRODUCT DESCRIPTION

BrightLine smart light box displays feature swift tool-free installation, durable light-weight frames, embedded LEDs, and exclusive One Planet recycled fabrics with impressive vivid graphics, all conveniently organized in a heavy-duty shipping case. Panel J is sized for versatile display opportunities, as a stand-alone banner, a closing sidewall, or seamlessly connecting to create popular 10ft and 20ft exhibits.

Mix-and-match with other BrightLine panels, or combine with WaveLine and StraightLine displays, to create unique branded environments. TV mounts and counters complete an enhanced experience to really make brands stand out.

KEY FEATURES

- Easy tool free assembly
- Lightweight portable construction
- Magnetic power links
- LED lights encapsulated in frame
- Heavy duty shipping case, molded foam inserts
- Single- or double-sided
- Vibrant graphics on recycled fabric

DISPLAY CONSTRUCTION

Aluminum frame with aluminum support poles

DIMENSIONS

Assembled Unit	40"w x 96"h x 4"d
Packed Case	46.5"w x 15"h x 8.7"d, 43 lbs
Shipping Box	47"w x 16"h x 10"d, 45 lbs
Graphic Size	40"w x 96"h

GRAPHIC MATERIAL

Graphic Print : Dye sublimated on One Planet, 100% recycled, backlit fabric	Bottles recycled 28
Blocker : One Planet light block recycled fabric	Bottles recycled 11

LED LIGHT SPECIFICATIONS

Power Requirements	64 W
CCT (Color Temp)	6000 K
Voltage Input	110 / 220V
Voltage Output	24V 4A 96W
Transformers Included	1

GRAPHIC FINISHING

Silicone sewn edges

WARRANTY

Limited Warranty Periods

- Frame : Lifetime
- Lights : 90 days
- Graphics : 30 days

PARTS

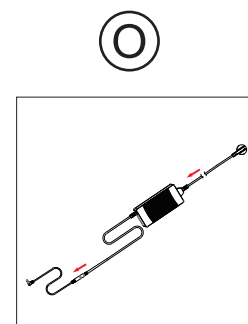
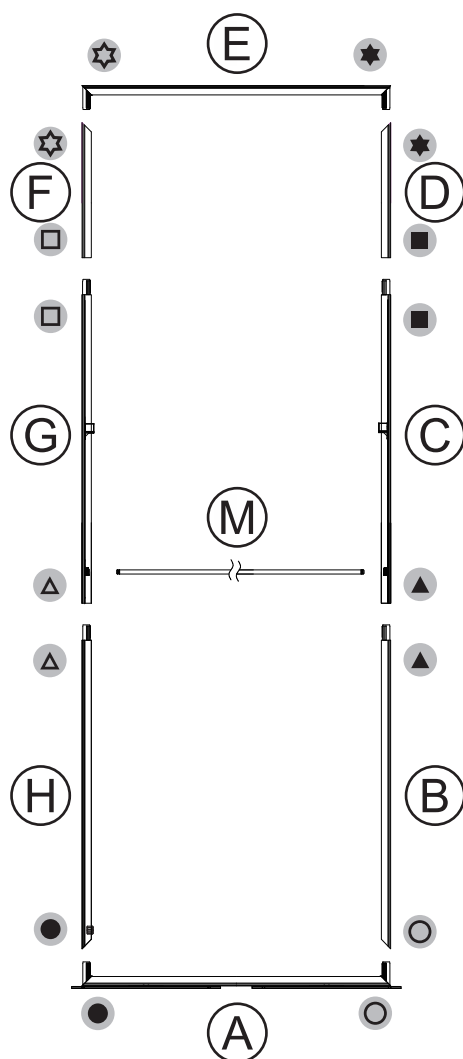
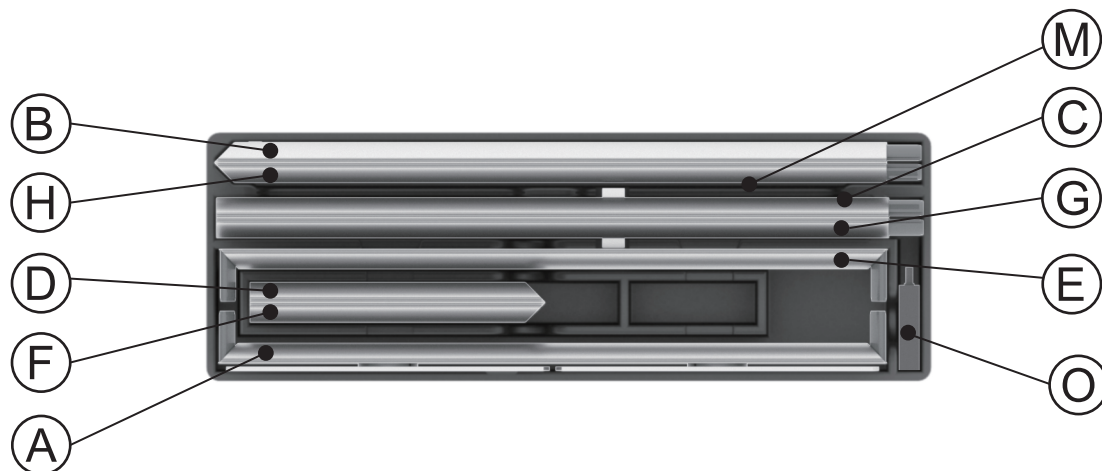

ASSEMBLY

Assemble parts on the floor and stand-up unit when completed.

1

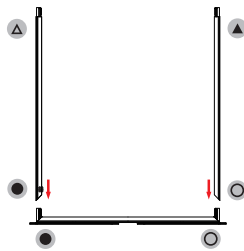
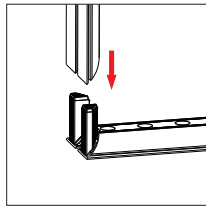

2

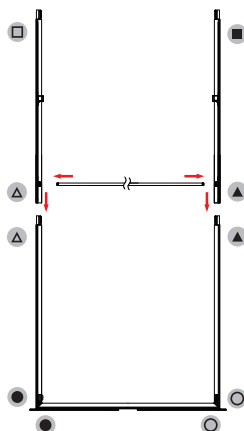
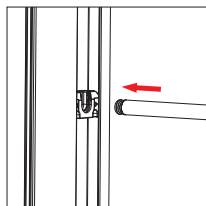

3

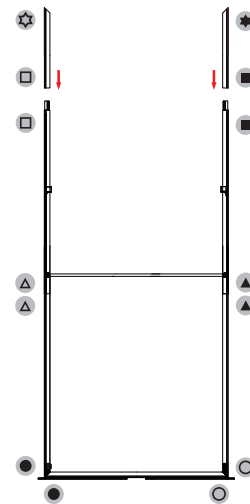
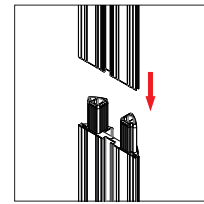

4

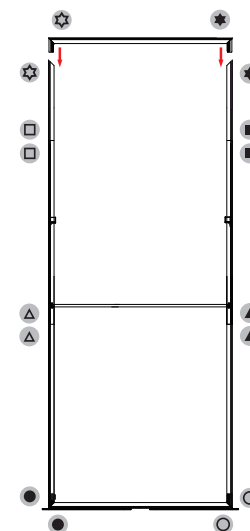
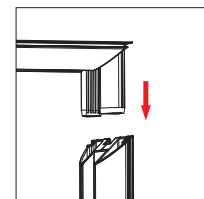

5 Push the silicone bead into each corner of the frame with your thumb.

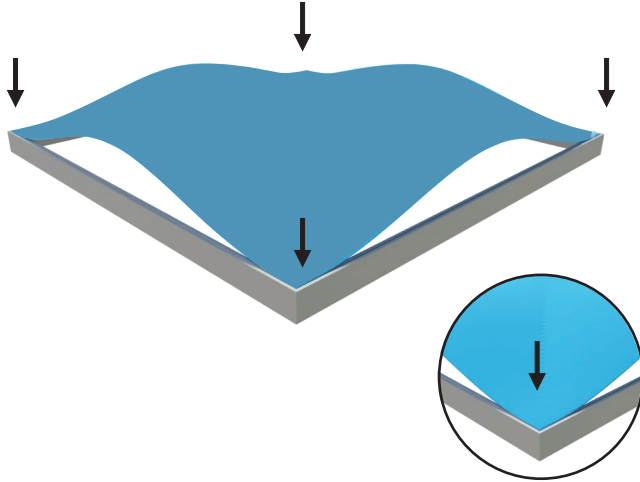

Push the silicone bead into the middle of the run and work your way around the perimeter of the frame until all beading is pushed in properly

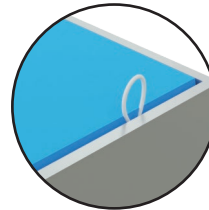
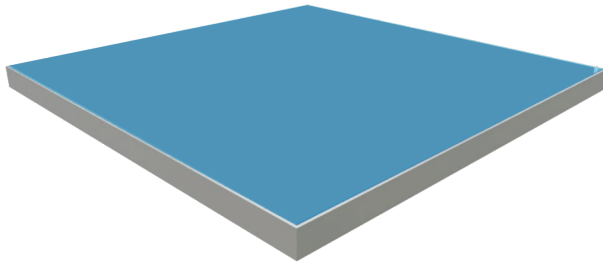
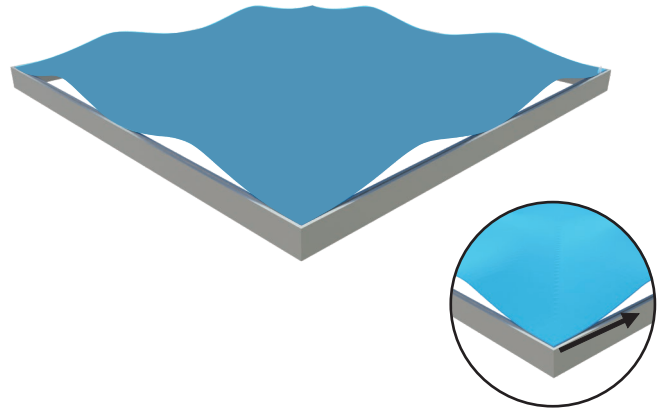

To Remove Graphic
Use the pull tab located on the graphic and gently pull the graphic from the frame, going around the perimeter

6

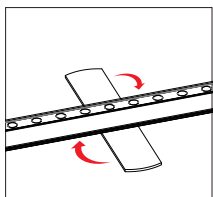
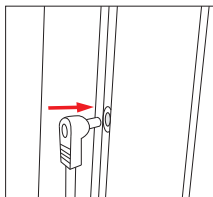



PRODUCT DESCRIPTION	
<p>Elevate any display with StraightLine J Doors, expertly crafted for both security and style. Featuring an anti-tampering keyless combination lock, they ensure safe and secure storage during events. Their sleek, modern design seamlessly integrates with StraightLine & BrightLine modular displays, providing a seamless integration. With One Planet Graphics, these doors come fully branded with double-sided graphics for enhanced brand visibility.</p> <p>Designed for effortless setup, the tool-free assembly saves time, while the collapsible design allows for easy packing into foam-lined shipping cases for ultimate portability. Offering the perfect blend of functionality and sophistication, StraightLine J Doors are an essential addition to any brand event or booth.</p>	

DISPLAY CONSTRUCTION	
Aluminum frame with aluminum support poles	

DIMENSIONS	
Assembled Unit	40"w x 89"h x 4" d
Packed Case	46.5"w x 15"h x 8.7"d, 44 lbs
Shipping Box	47"w x 16"h x 10"d, 46 lbs
Graphic Size	40"w x 89"h

KEY FEATURES	
<ul style="list-style-type: none"> • Modular system • Easy tool free assembly • Lightweight portable construction • Anti-tampering keyless combination lock 	<ul style="list-style-type: none"> • Heavy duty shipping case, molded foam inserts • Includes 2 printed graphics • Vibrant graphics on recycled fabric

GRAPHIC MATERIAL	
Graphic Print : Dye sublimated on One Planet, 100% recycled, fabric	Bottles recycled 48

GRAPHIC FINISHING	
Silicone sewn edges	

WARRANTY	
Limited Warranty Periods - Frame : Lifetime - Graphics : 30 days	

PARTS

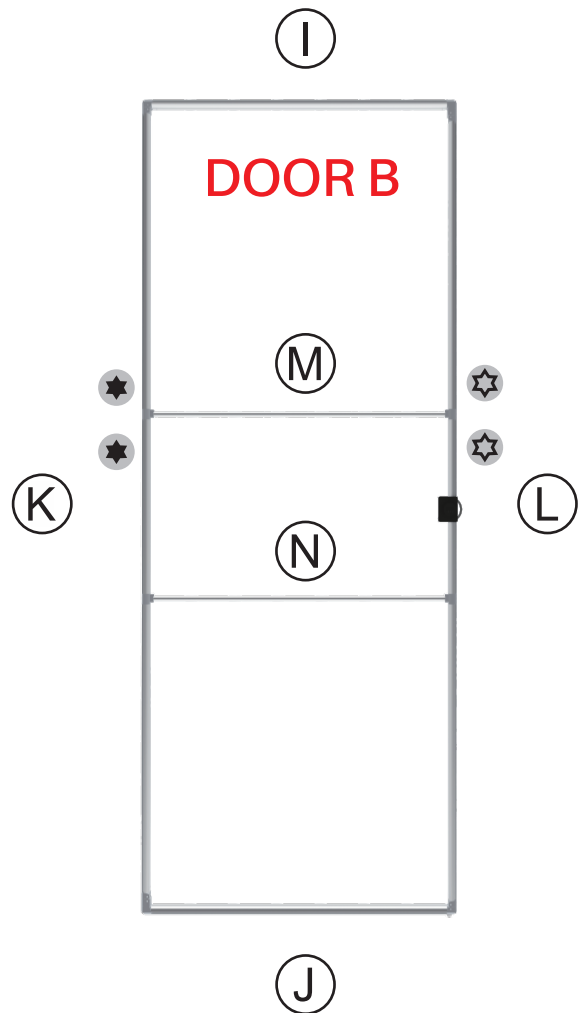
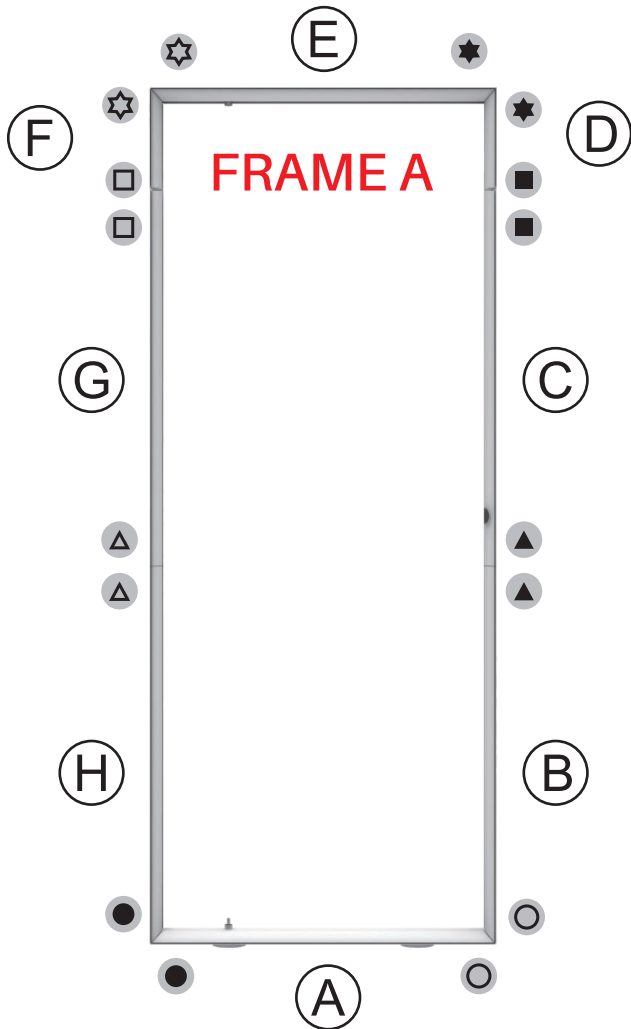
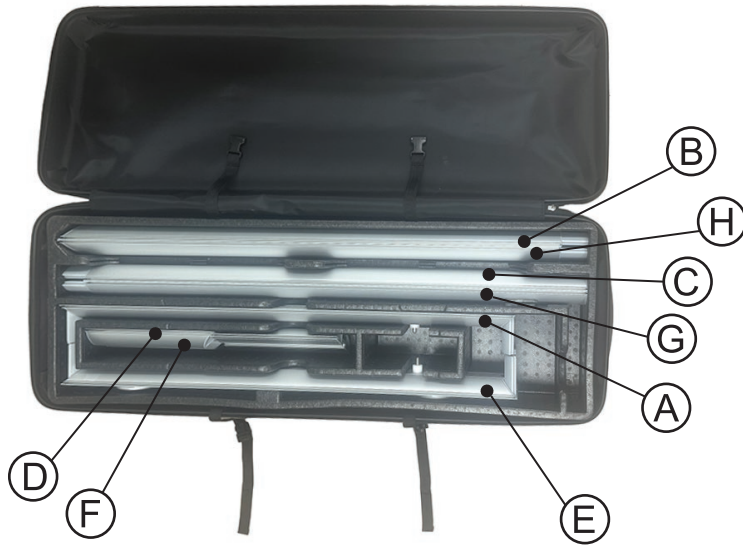

ASSEMBLY

Assemble parts on the floor and stand-up unit when completed.

1

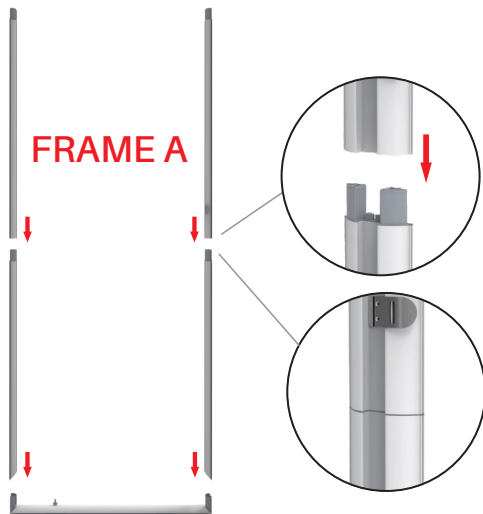

3

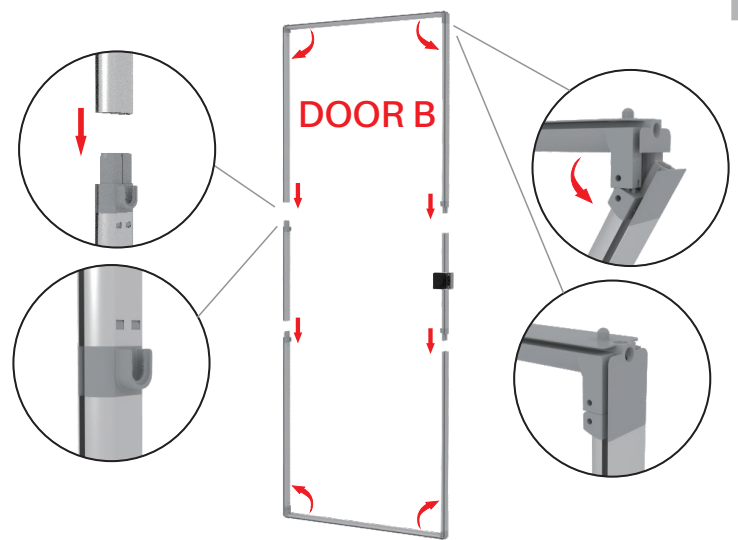

2

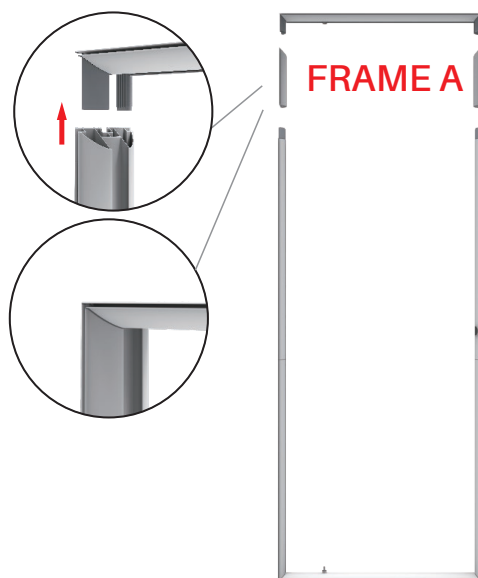

4

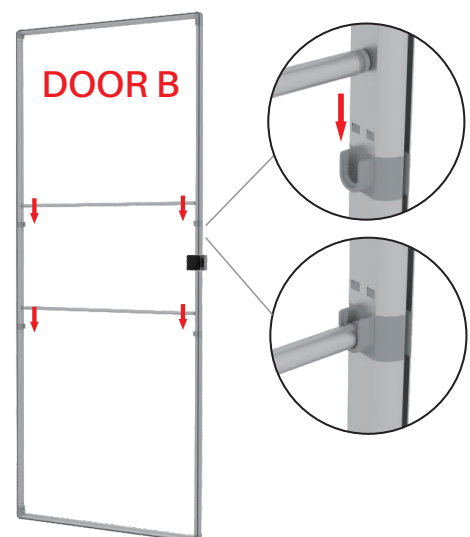

ASSEMBLY

Assemble parts on the floor and stand-up unit when completed.

5

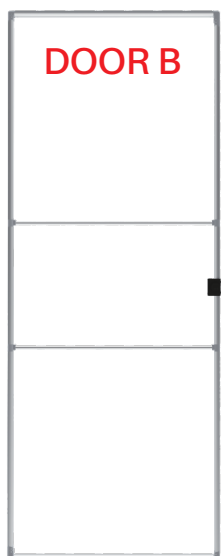

7



6

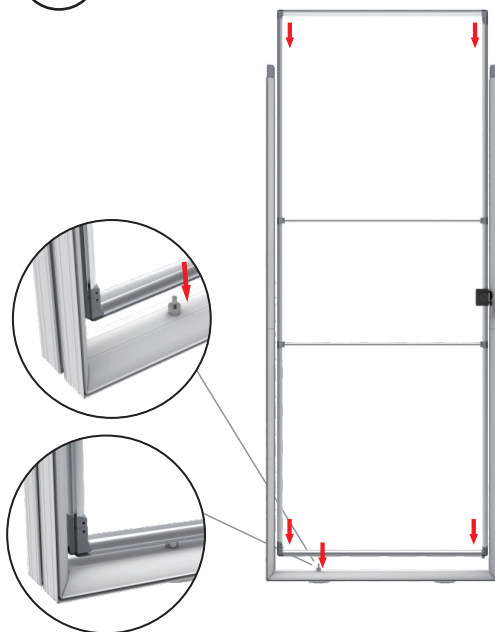

8



9 Push the silicone bead into each corner of the frame with your thumb.

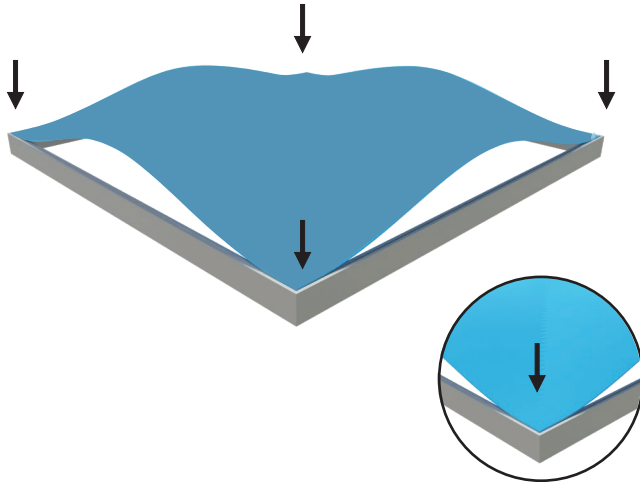

Push the silicone bead into the middle of the run and work your way around the perimeter of the frame until all beading is pushed in properly

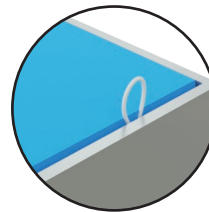
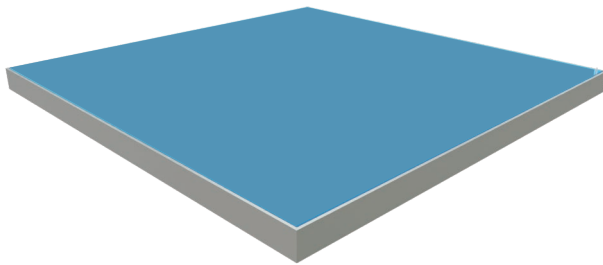
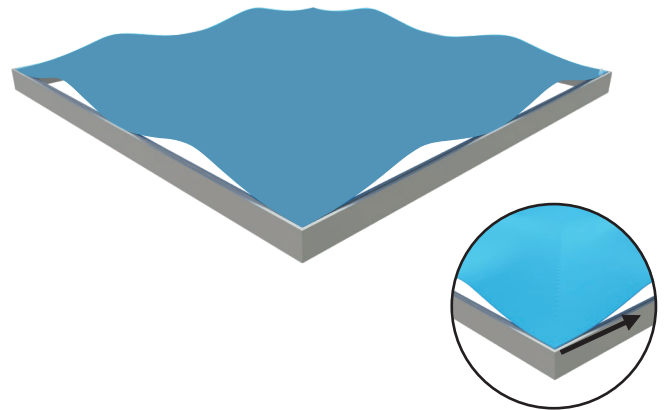

To Remove Graphic
Use the pull tab located on the graphic and gently pull the graphic from the frame, going around the perimeter

10



Turn to default passcode (000) and twist knob to unlocked position



Insert pin in the reset hole on the side and keep pressing while setting new passcode



Release and remove pin from hole

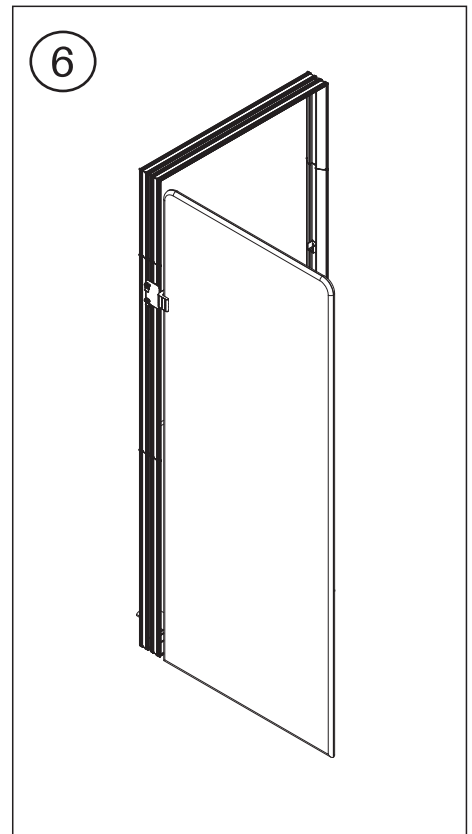
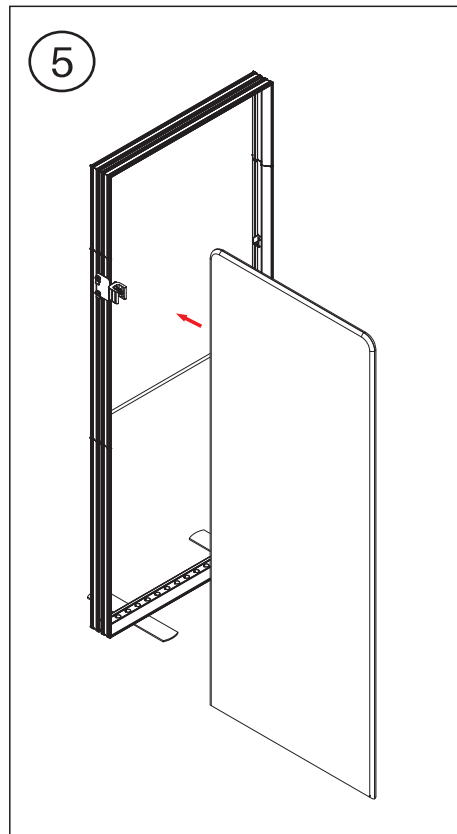
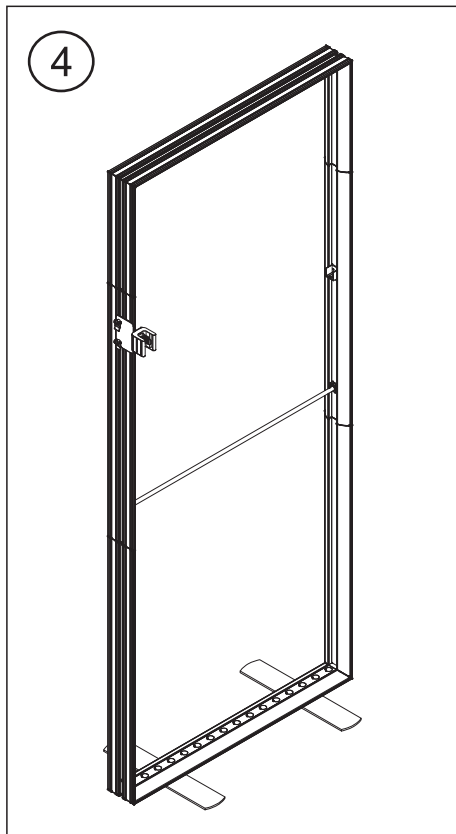
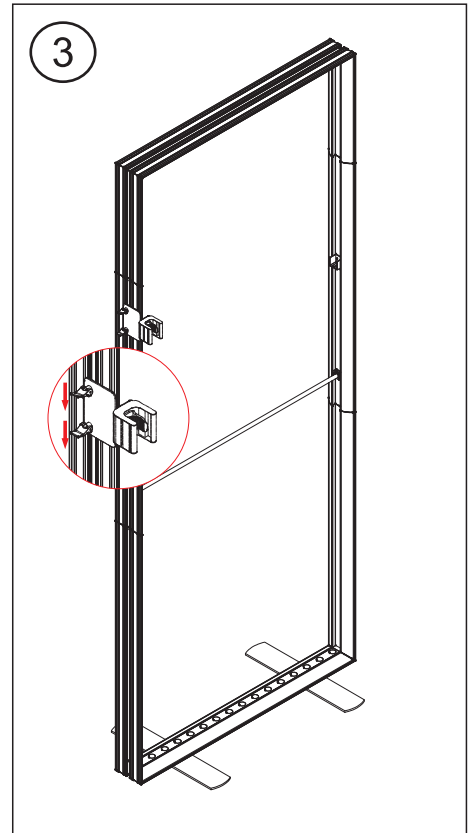
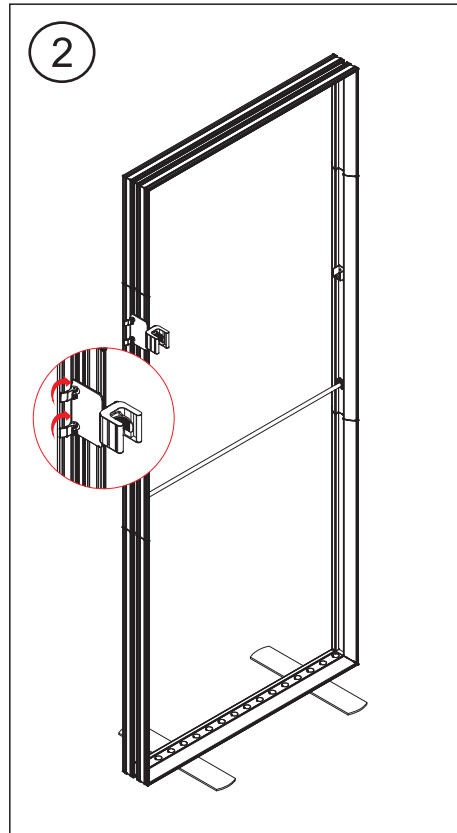
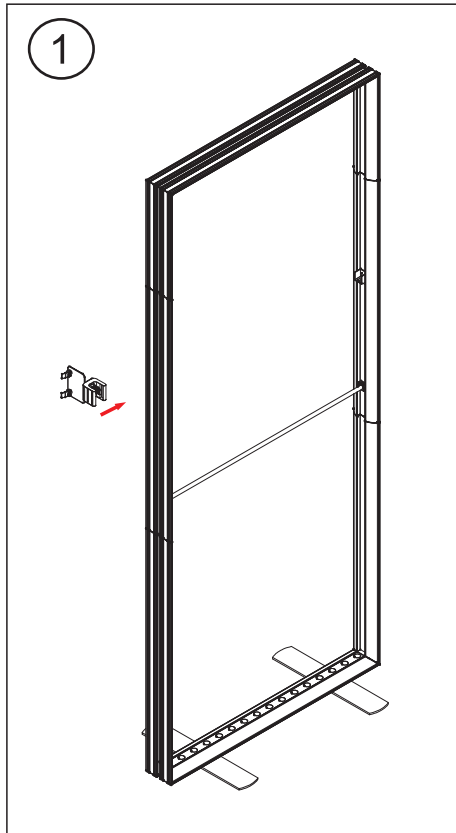

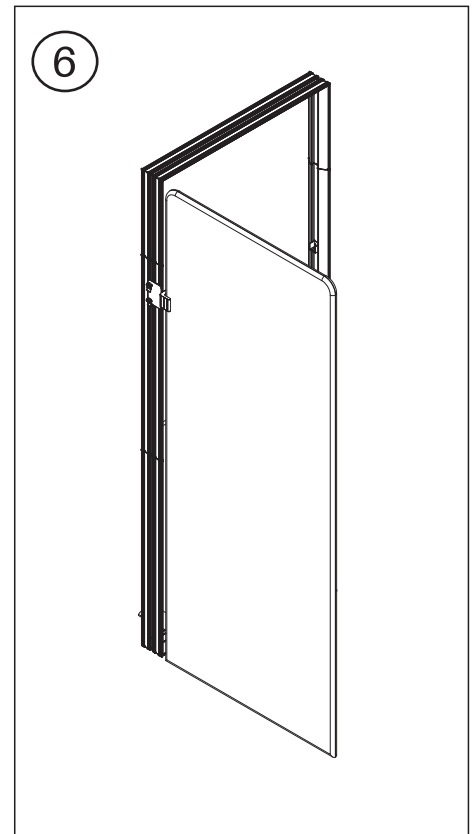
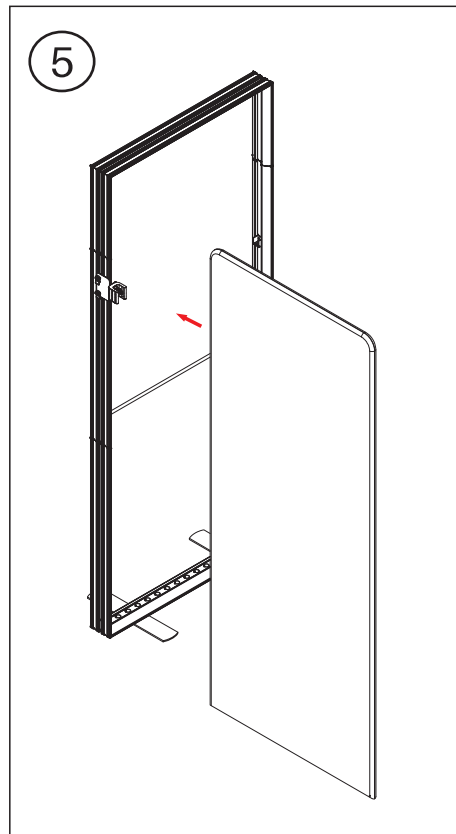
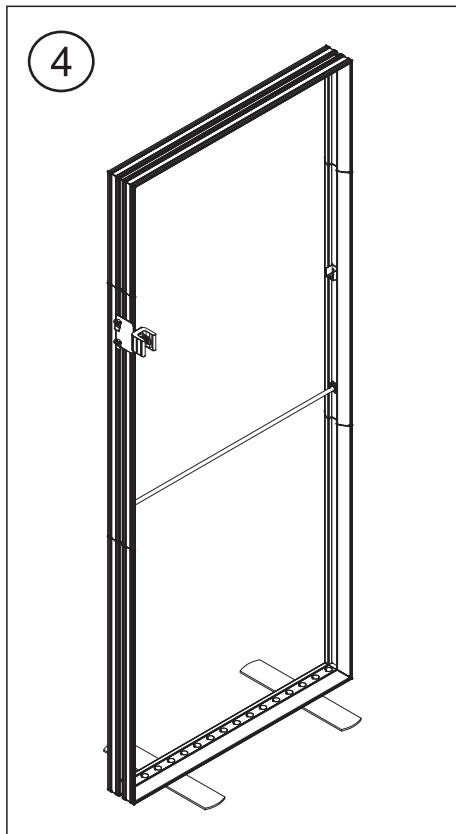
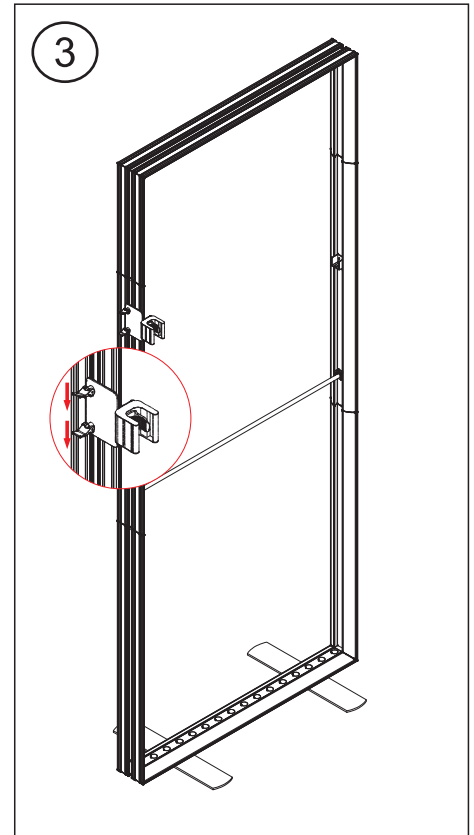
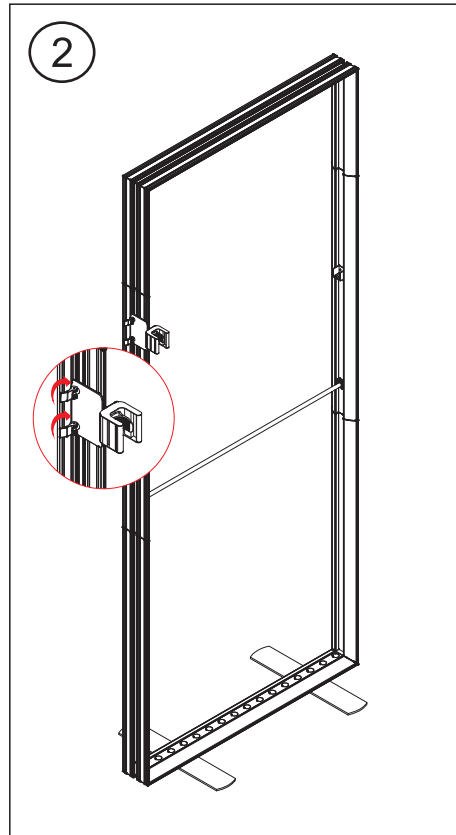
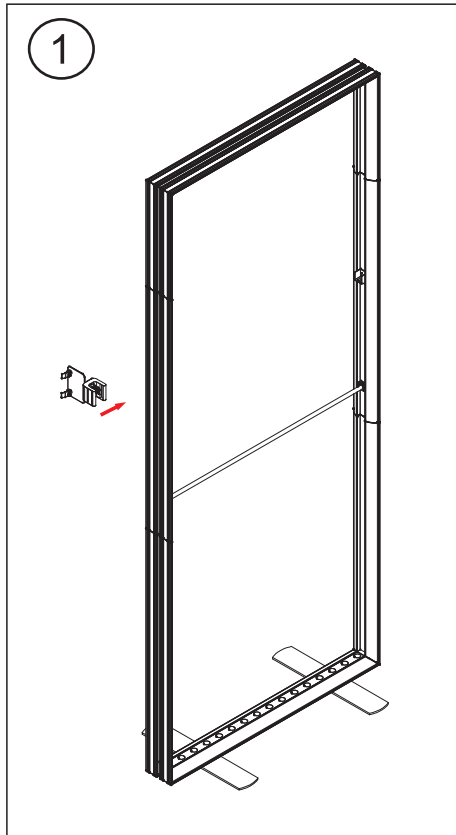

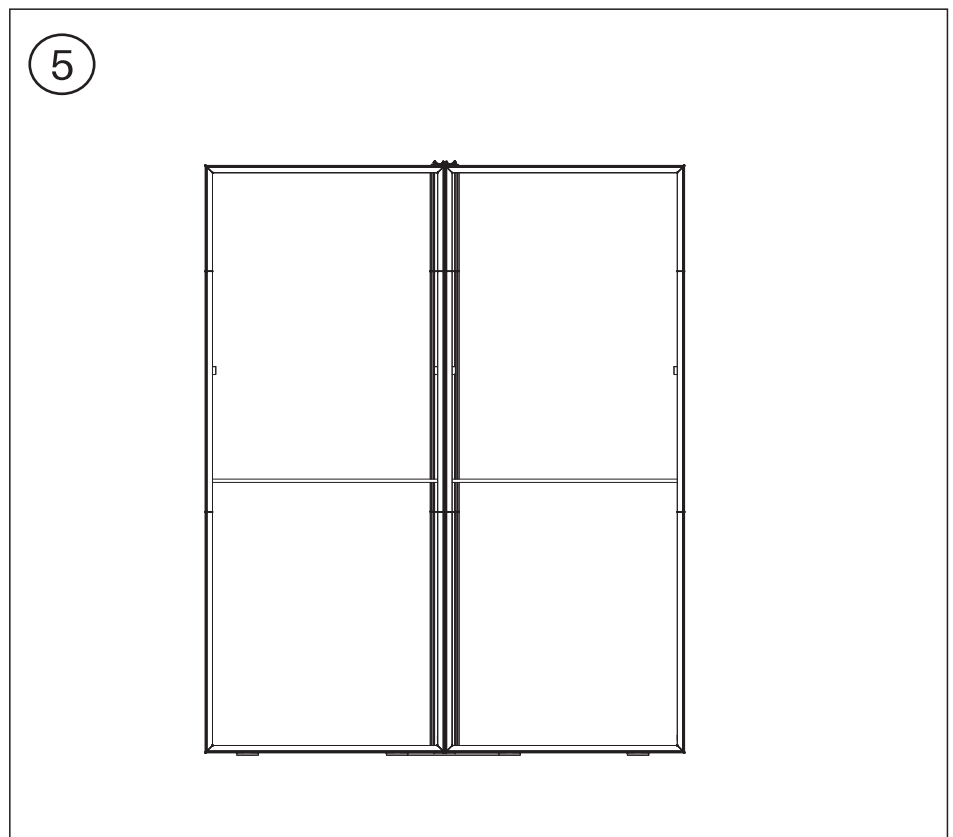
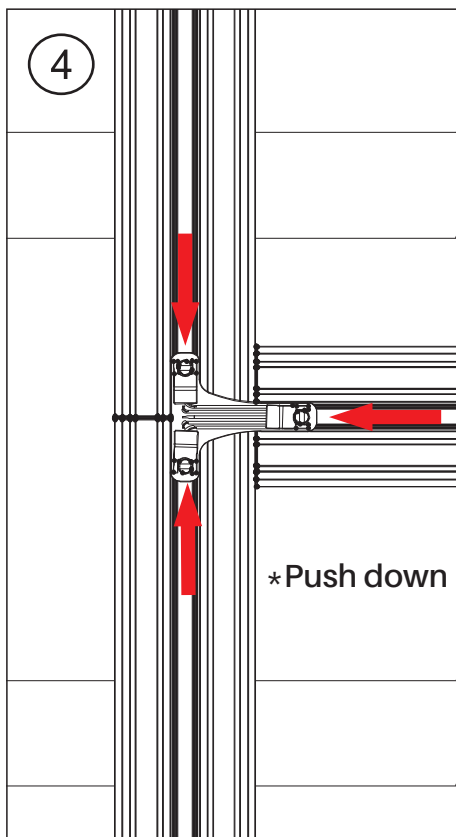
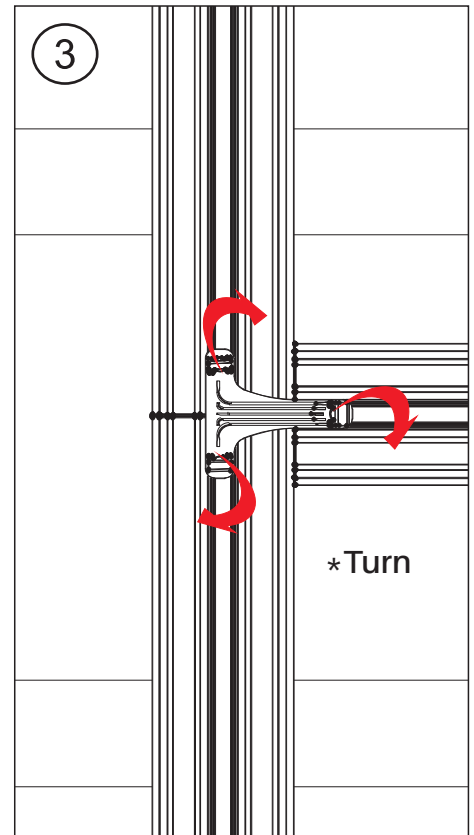
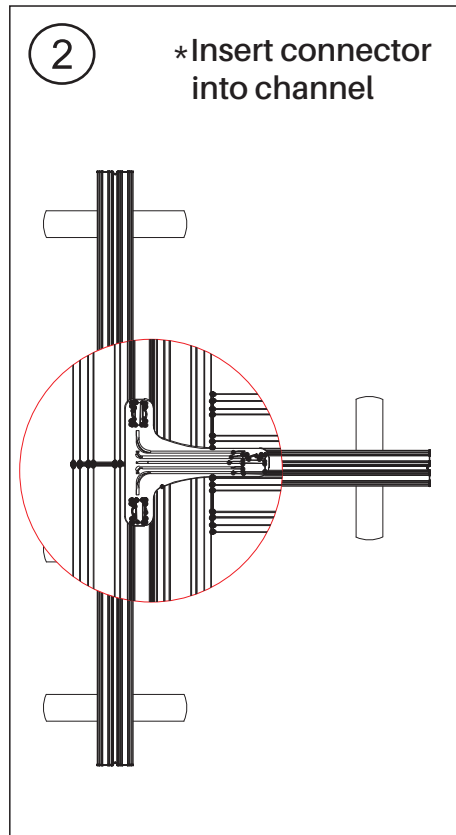
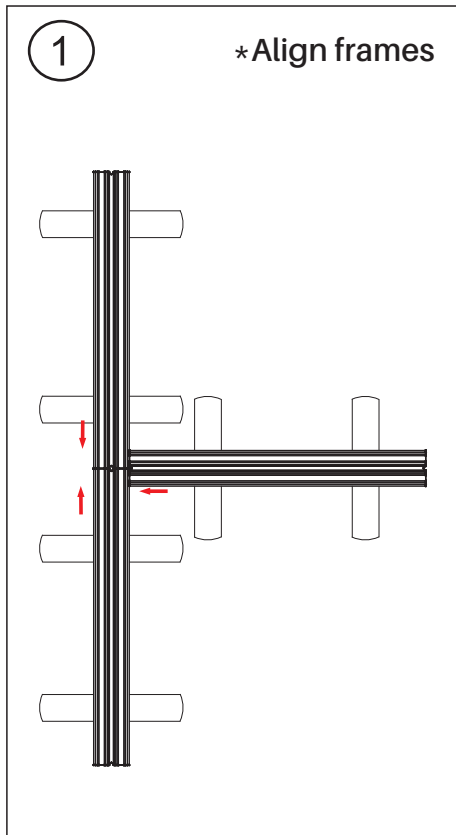

Counter
BLM-COUNTER-K

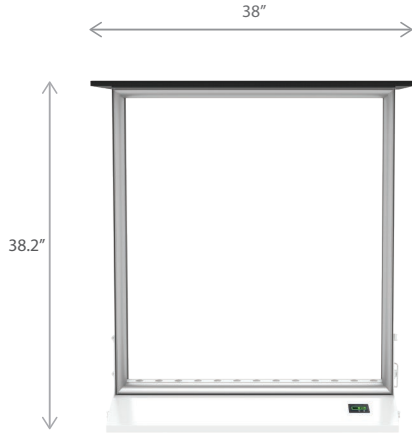

PRODUCT DESCRIPTION

The BrightLine backlit counter stands as a beacon of sophistication, seamlessly blending illumination, and functionality. Its sleek design, showcasing double-sided graphics, creates an ambiance that draws attention. Complete an inviting environment with brilliant counters showcasing double-sided branding and ample countertops that fit laptops or tablets.

Upgrade to the cordless version, where the base is loaded with rechargeable batteries that last over 12 hours. Whether in a showroom, a tradeshow exhibit, or a retail environment, the backlit counter defines a modern elegance and functionality in perfect harmony.

KEY FEATURES

- Easy tool free assembly
- Lightweight portable construction
- Magnetic power links
- LED lights encapsulated in frame
- Heavy duty shipping case, molded foam inserts
- Single- or double-sided
- Vibrant graphics on recycled fabric

DISPLAY CONSTRUCTION

Aluminum frame with aluminum support poles

DIMENSIONS

Assembled Unit	38" w x 38.2" h x 15.8" d
Packed Case	43" w x 23" h x 13.5" d, 59 lbs
Shipping Box	44" w x 23" h x 14" d, 61 lbs
Graphic Size	33" w x 36" h
Countertop	38" w x 0.625" h x 15.75" d
Base	33" w x 1.6" h x 15" d
Graphic Frame	33" w x 36" h x 4.8" d

GRAPHIC MATERIAL

Graphic Print : Dye sublimated on One Planet, 100% recycled, backlit fabric	Bottles recycled 9
Blocker : One Planet light block recycled fabric	Bottles recycled 4

GRAPHIC FINISHING

Silicone sewn edges

LED LIGHT SPECIFICATIONS

Power Requirements	64 W
CCT (Color Temp)	6000 K
Voltage Input	110 / 220V
Voltage Output	24V 4A 96W
Transformers Included	1

WARRANTY

- Limited Warranty Periods
- Frame : Lifetime
 - Lights : 90 days
 - Graphics : 30 days

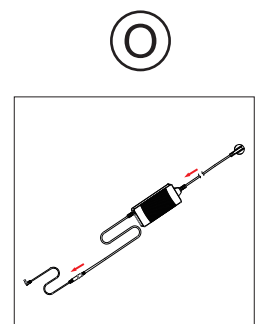
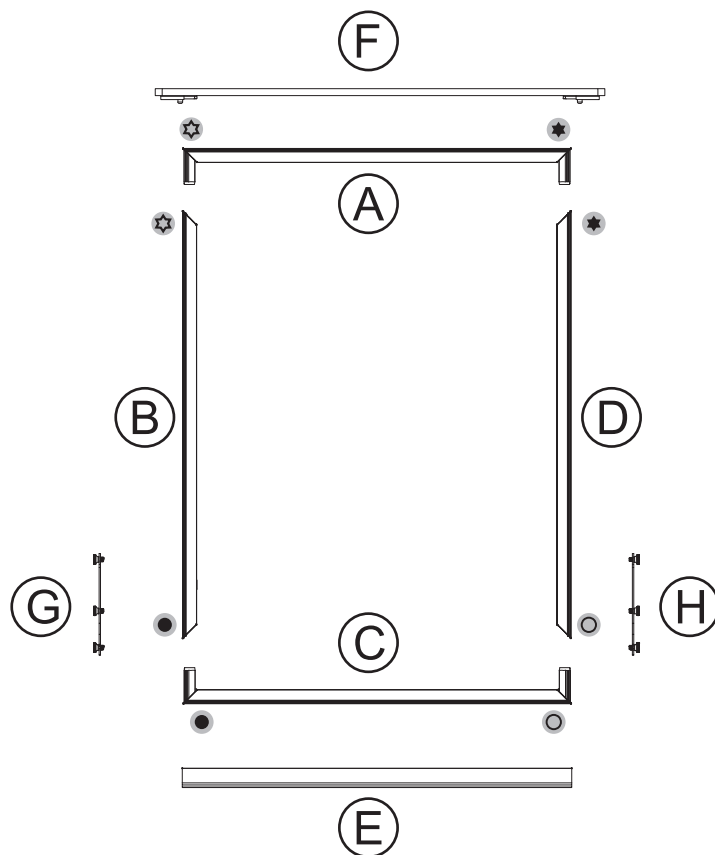
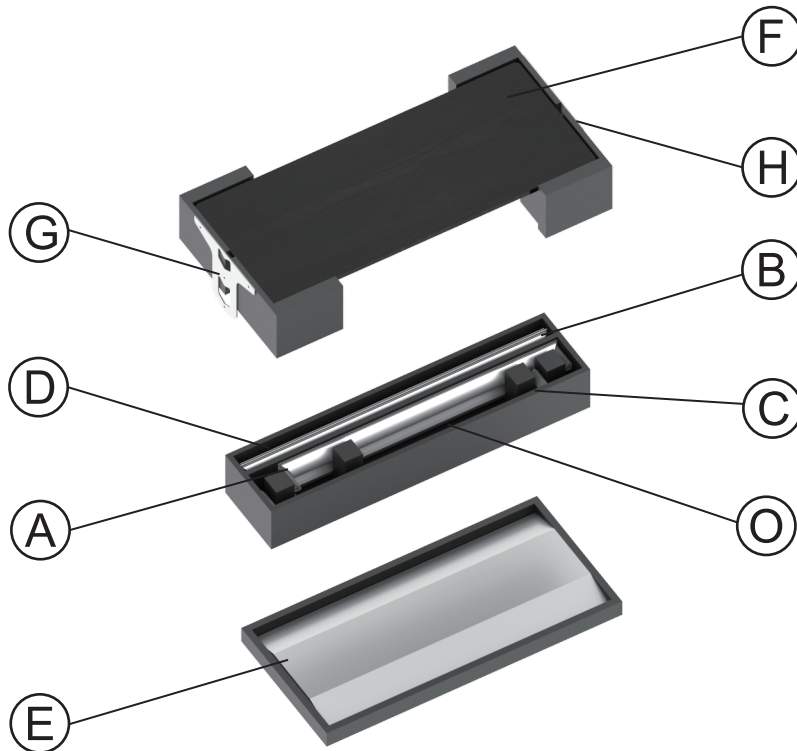

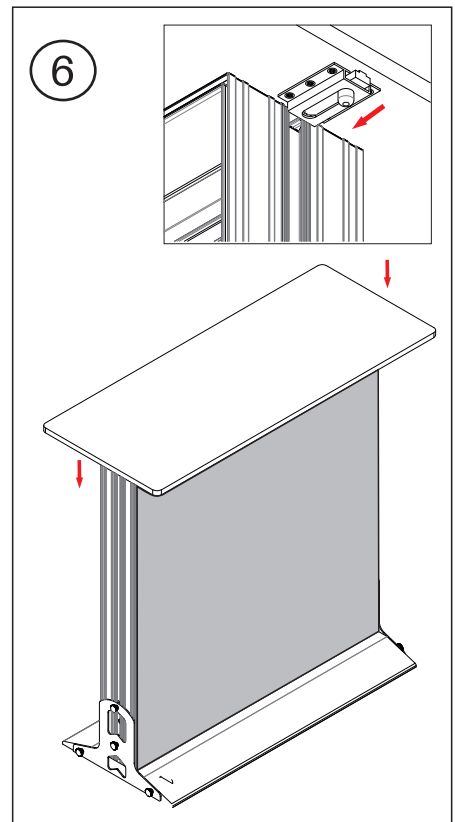
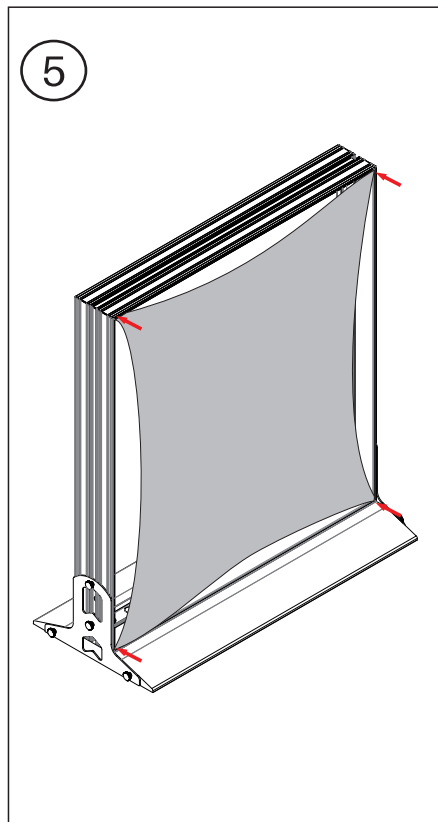
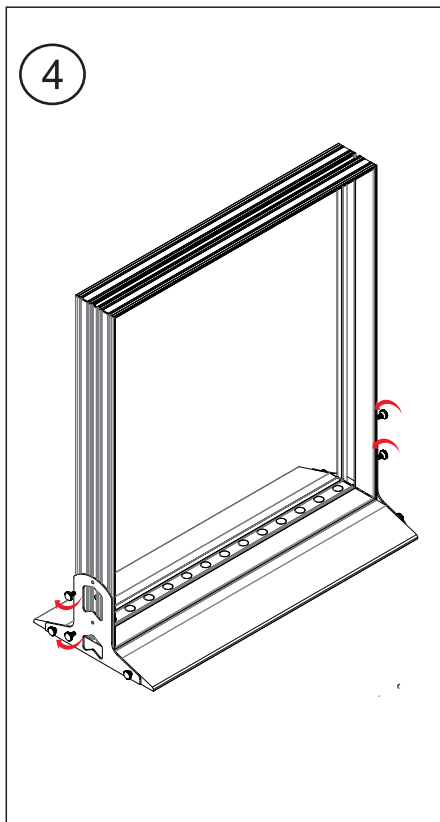
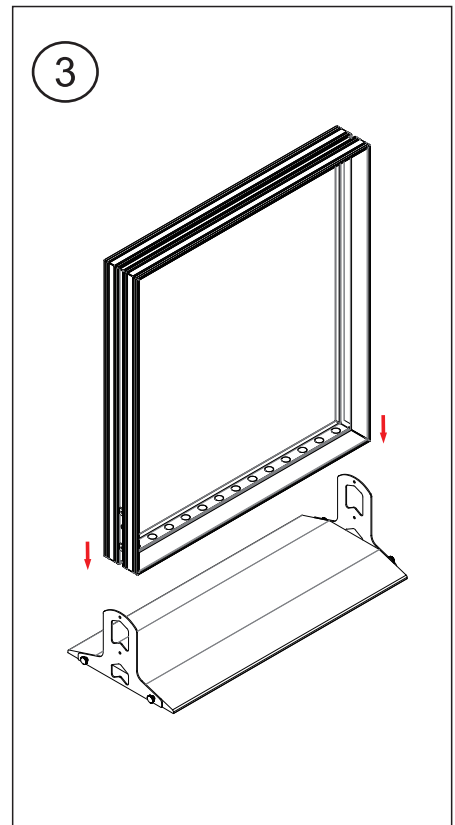
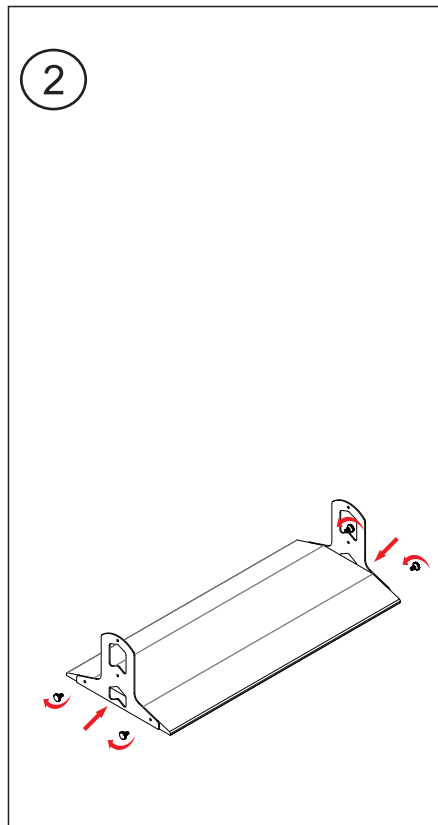
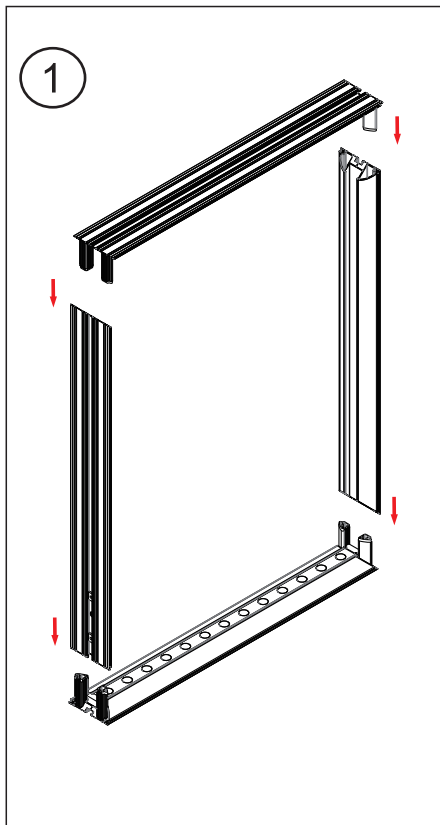

Waterfall 36" XL

WFA36-XL



OPTIONAL Shelving



PARTS INCLUDED



Aluminum Frame



Graphic



Support Feet x2



WLM-CM90 Clamp x1



OPTIONAL Shelving

PRODUCT DESCRIPTION

The WaveLine Waterfall features a robust aluminum frame with choice of partial or full graphics. Its durable aluminum poles are supported by sturdy feet. Graphics are printed on exclusive One Planet recycled fabric. Upgrade with optional shelving for more functionality.

KEY FEATURES

- Provides additional depth and functionality
- Easy tool-free assembly
- Durable aluminum poles
- Partial or full graphics
- Vibrant graphic prints on recycled fabrics
- Convenient optional shelving

DISPLAY CONSTRUCTION

Aluminum frame with aluminum support poles

GRAPHIC FINISHING

Top grade YKK zippers along bottom of display

GRAPHIC MATERIAL

Graphic Print :
Dye sublimated on One Planet, 100% recycled, fabric

Bottles recycled
123

DIMENSIONS

Assembled Unit	36" w x 89" h x 107" d
Graphic Size	36" w x 196" h
Shipping Box	36" w x 14" h x 14" d, 20 lbs
Optional Shelves	Call for details!

WARRANTY

Limited Warranty Periods
- Frame : Lifetime
- Graphics : 6 months

Waterfall 36" XL

WFA36-XL

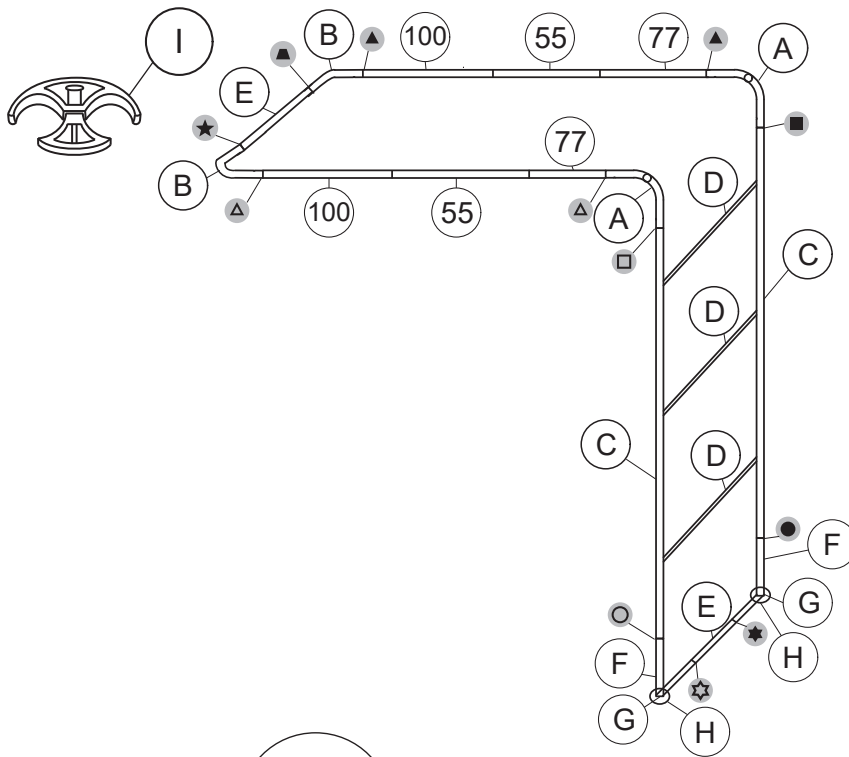

36"XL Waterfall		
Qty.	Part Number	Key
2	WLM#90	(A)
2	WLM#90-1	(B)
2	WLM#05	(C)
3	WLM#80	(D)
2	WLM#76	(E)
2	WLM#35	(F)
2	WLM#18	(G)
2	WLM#23	(H)
2	WLM#100	(100)
2	WLM#55	(55)
2	WLM#77	(77)
1	WLM-CM90	(I)

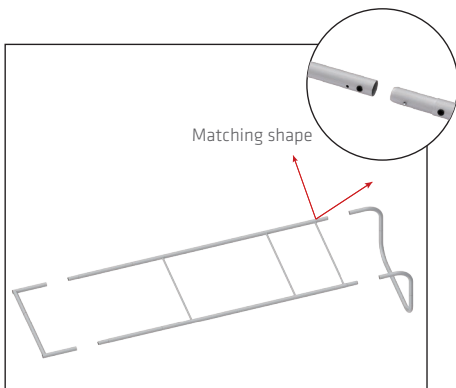

1. Connect poles by pressing and pushing. Connect corner sections to straight sections with matching shape codes.

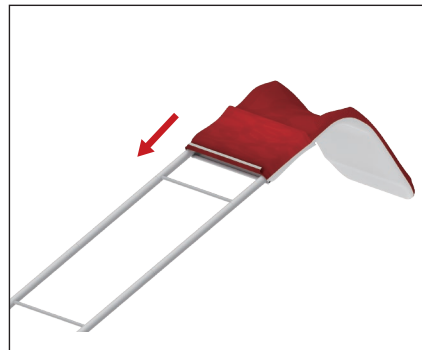

2. Unzip print and lay image face up. Slide print onto frame like a pillow case.

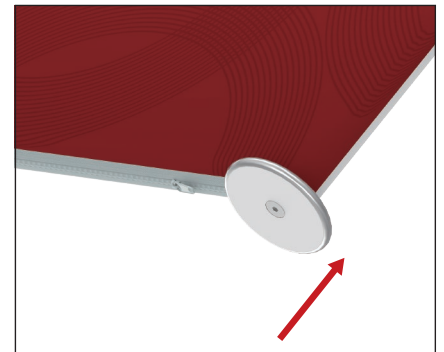

3. Connect feet by pressing and pushing. Zip the bottom edge of the graphic beyond the center point as shown above.



4. Position frame as desired and clamp in place.

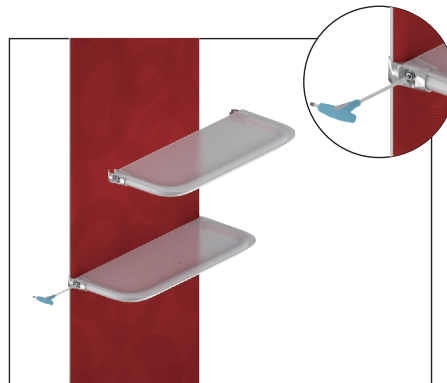

5. *OPTIONAL* Shelves come semi assembled, make sure to level before tightening the clamp.



6. Enjoy!

WAVELINE®

10'w x 3'h WL Hanging Sign

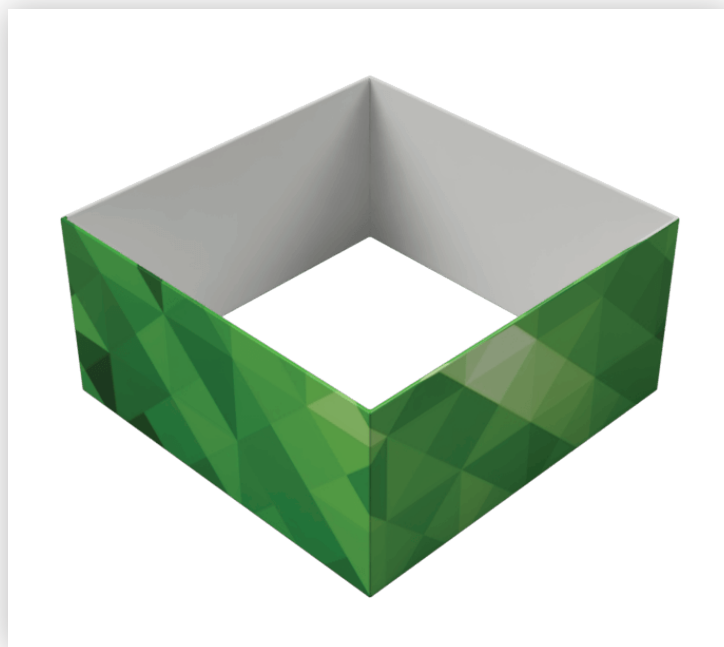
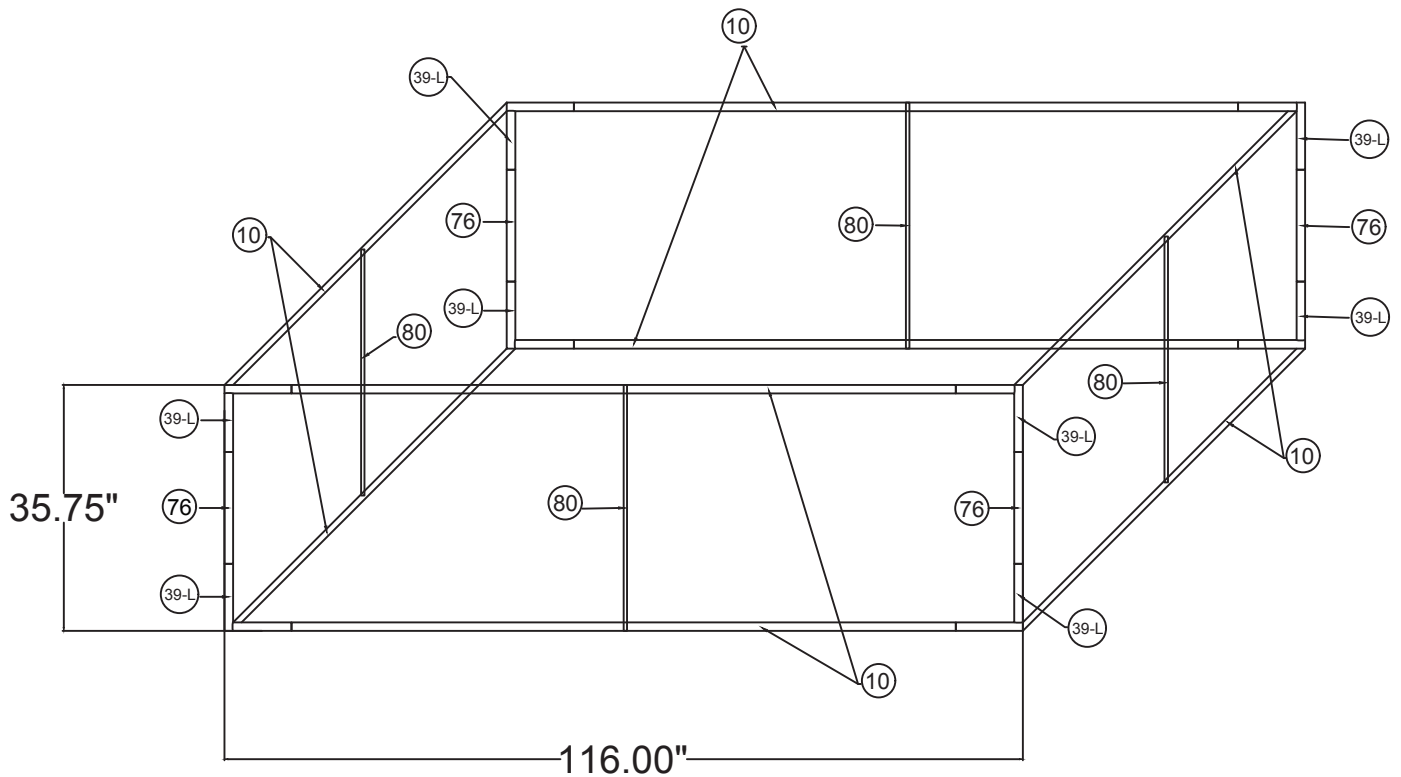

SHS1036

10'w x 3'h WL Hanging Sign	
Qty.	Part Number
8	WLM#039L-US
4	WLM#076
4	WLM#080
8	WLM#010
1	BGO-FABRIC-L bag

Notes:

- * Does not include Hanging Cables
- * Will fit inside a CA600 or CA900 case

WAVELINE®

Hanging Sign Rigging Instructions

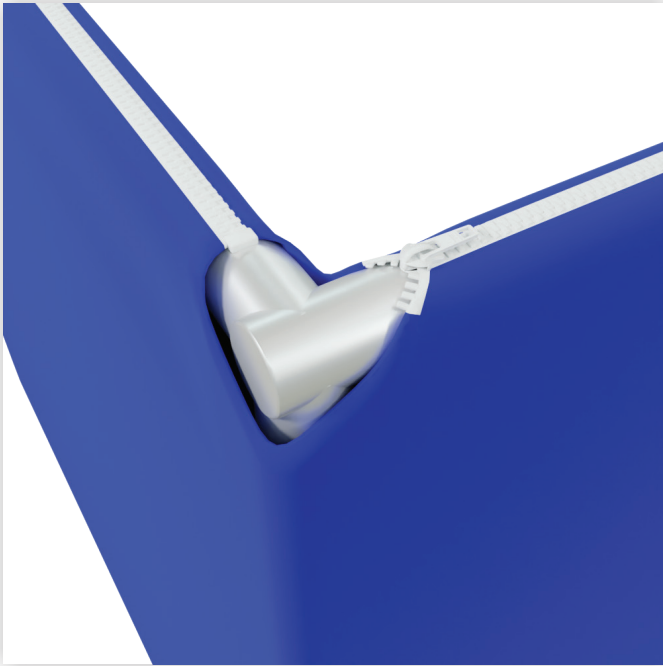

Step 1

After assembling the sign, locate the hanging points. There are openings on the zipper to allow for cables to be inserted



Step 2

Open the zippers to expose the hanging area, then wrap the cables around the vertical support pole

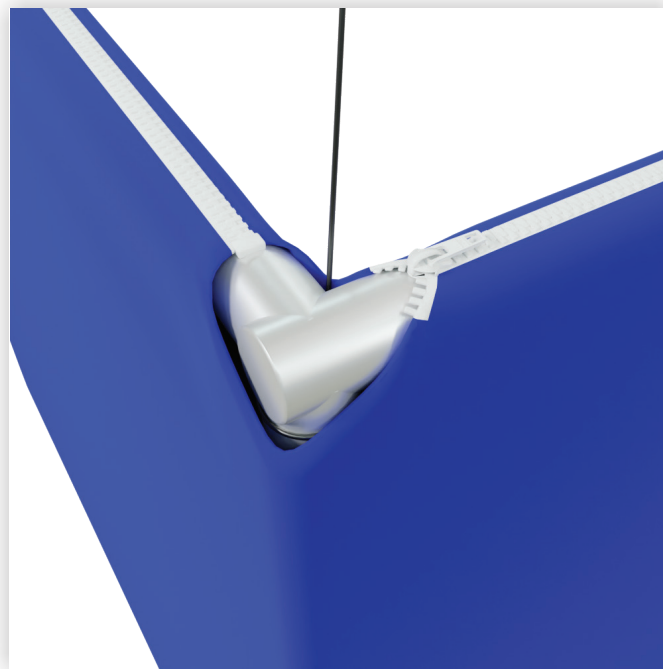

Step 3

Pull the cable through the opening in the fabric. Close the zippers.

*Hanging cables are not included in the kit, to be provided by on-site rigging team.